

# MINISCALE INSTALLATION

## I. INTRODUCTION

Apparently most installers only read the installation instructions when they run into trouble. For this reason the most important points -- the ones most likely to result in damage -- have been put in section II. **READ THIS BEFORE STARTING.**

Installers are strongly advised to read section II before attempting to install miniscales.

### CAUTION

**It is important to properly install the miniscales, as described in this manual. Failure to do so may result in severe miniscale damage.**

**WARRANTY DOES NOT COVER FAULTY INSTALLATION!**

If the system was mounted by the supplier before being shipped and it does not work upon arrival:

1. Check for any damage which may have occurred during shipment.
2. Contact the freight company as soon as possible to report any potential damage.

### Miniscale Components

1. Spar.
2. Encoder Box which travels along the spar.
3. Cable for power to miniscale and output from miniscale.
4. Connector to digital readout.
5. Alignment bracket.
6. Endcap.
7. Endcap which can be used in place of alignment bracket after installation, if desired.

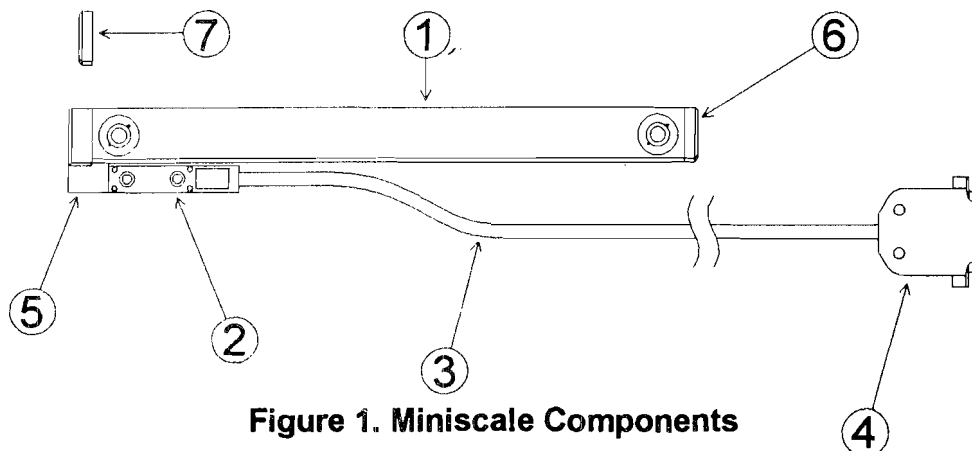

**Figure 1. Miniscale Components**

## II. READ THIS BEFORE STARTING

- Miniscales contain precision electronic and glass components. Do not drop, bend or hammer on the miniscales.
- Before beginning installation, verify that your miniscales have the correct travel. The overall miniscale length is not the travel. The travel is specified by the part number. Example: An XT350-12 miniscale has a 12 inch travel. Overall length is 16 inches (12 + 4).
- Do not loosen or remove the alignment bracket until installation is complete. The alignment bracket is designed to simplify installation. For installation, position the table to its maximum travel in one direction. See Figure 6 for example. If a special application requires removing the alignment bracket to slide the encoder box over, call the factory for an optional encoder box slide bracket.
- The miniscale may be mounted to a machined surface providing the surface is parallel to the table movement.
- Do not mount the spar directly to an uneven surface. Use a backplate if the surface is not an accurately machined surface. See Figure 7 for example.
- The machine must have mechanical stops that prevent overtravel. Mount stops if necessary. Do not remove stops after miniscale is installed. If table travel is greater than the specified miniscale travel, contact your dealer to obtain the correct travel length miniscale.
- Do not offset the miniscale (extra travel on one end, insufficient travel on the other end). This is prevented by:
  1. Having the correct travel miniscale, AND
  2. Moving the table all the way to its mechanical stop before the miniscale is installed, AND
  3. By not removing the alignment bracket until installation is complete.
- Do not drill holes at an angle. Do not improperly space holes. These errors may cause bowing or sagging of the miniscale. See Figure 2.

**CAUTION**

**Mounting holes are normally transfer punched to locate the proper hole location. Since these holes are hand drilled, it is advisable to begin by drilling a smaller guide hole to prevent the larger drill bit from "walking".**

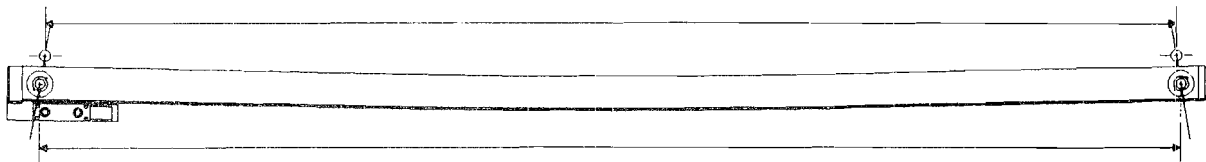

**Figure 2. Improper Drilling**

- Use a micrometer or dial indicator to indicate the front and the top of the spar surface. The spar must be parallel to the table travel to within 0.005 inch, in both planes, over the entire travel of the miniscale.

- Adjust encoder box set screws before tightening the mounting screws. The encoder box must be centered relative to the spar. See Figure 3. The alignment bracket ensures that the encoder box is properly positioned. Keep the alignment bracket secured until installation is complete.

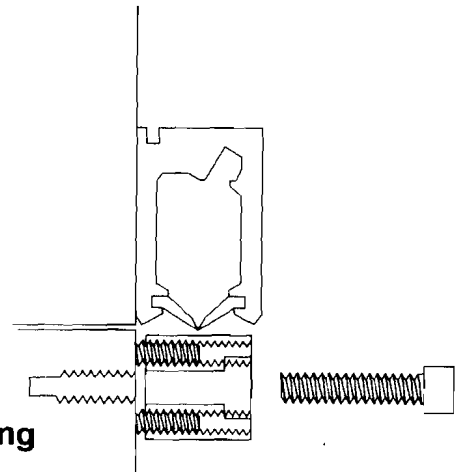

**Figure 3. Encoder Box Mounting**

- Do not cock the encoder box. Parallelism must be maintained. See Figure 4.

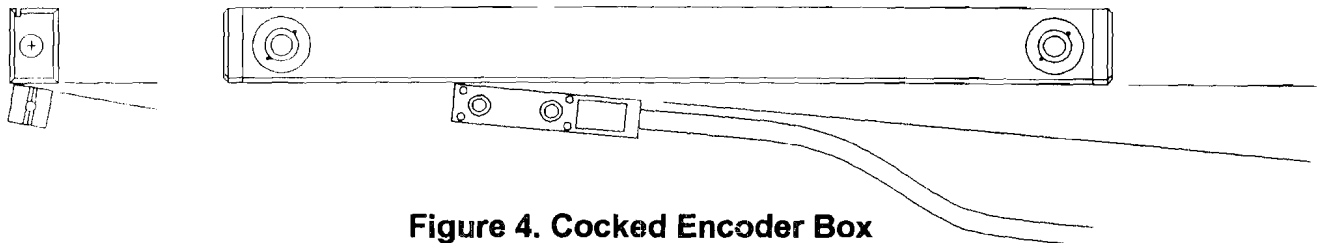
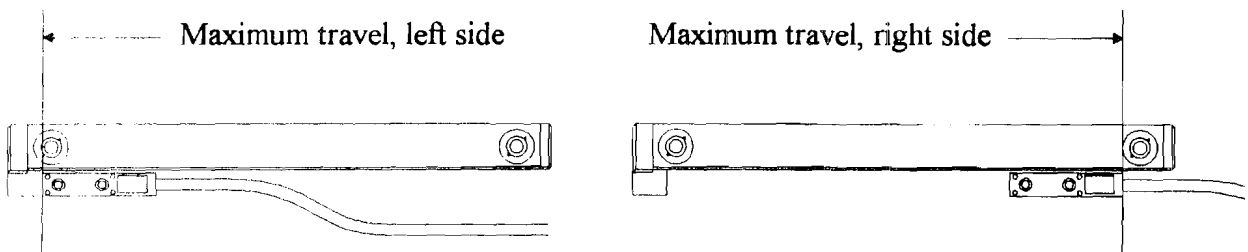

**Figure 4. Cocked Encoder Box**

- After installation, verify that it is not possible to overtravel the miniscale. The maximum left travel is the same with or without the alignment bracket. See Figure 5.

**CAUTION**

**Overtraveling the encoder box will result in severe damage. The miniscale does not have "stops" in it. The alignment bracket cannot be used as a mechanical stop.**



**Figure 5. Maximum Miniscale Travel**

- Do not leave miniscale cables hanging loose. They may be caught and pulled out. Dress and secure with tie-wraps and cable anchors.

### **III. GENERAL**

---

The following sections describe installation procedures for Bridgeport/Lagun type kneemills. The same guidelines are applicable for lathes (where miniscales are used), grinders, EDMs, comparators, etc.

#### **Hardware**

For systems that include hardware kits, the part number is located on the hardware kit box and on the corresponding hardware drawing. Verify that you have the correct hardware kit and drawing for your application.

Machines vary from type to type. Also, machine manufactures may change specifications without notice. For these reasons, installation hardware may require some modification. Due to the dynamic nature of the machine tool industry, hardware kits and drawings are subject to change without notice.

Other machine types may require special hardware fabrication; however, actual miniscale installation follows the same guidelines. The installer must maintain the specified spar alignment tolerances to achieve optimal performance and accuracy. Custom installations may be completed by the end user without assistance; however, factory assistance is available if necessary.

Standard machine shop practices should be used always; for example, safety, set up, cleaning of fluids, swarf, etc.

#### **Mounting Area**

The miniscale may be mounted directly to a flat, accurately machined surface such as the back of the table on a mill, providing the surface is parallel to the table travel. If the surface is not flat, such as the Y axis mounting surface on a mill (the knee) or the bed of a lathe, then the use of a backplate (included with most mill hardware kits for Y axis travel) is required. Also, the use of shim stock between the miniscale and the table surface can correct minor deviations. Adjustment must also be made for any obstructions such as oil lines, power feeds, etc.

#### **Cable Routing**

The miniscale may be mounted with the cable exiting in either direction. Mounting considerations and miniscale cable routing must be taken into account by the installer to determine which orientation is best.

## IV. MILL - X AXIS MINISCALE INSTALLATION

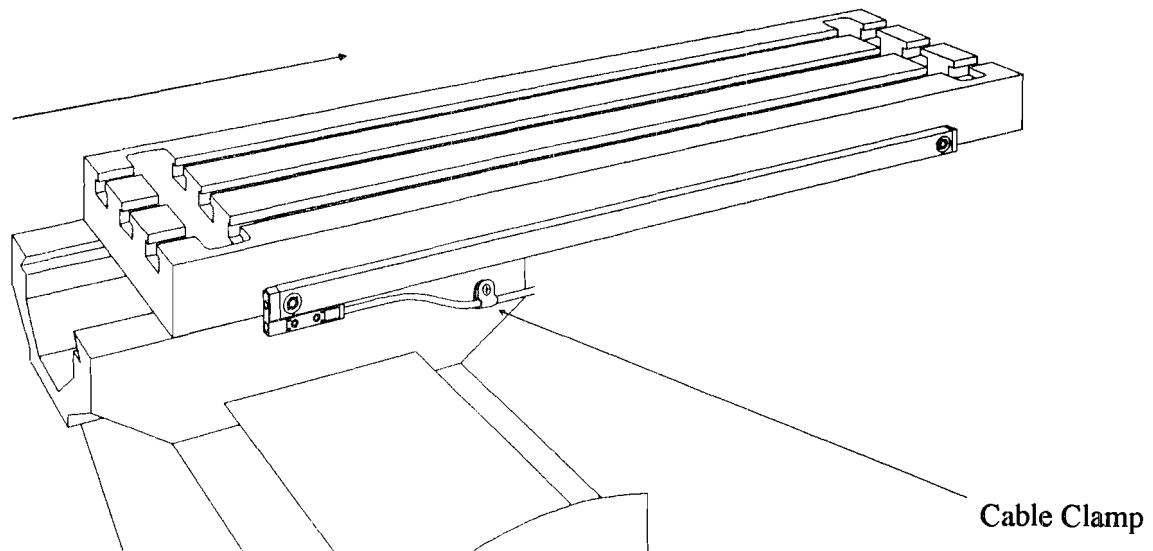

Figure 6. X Axis Miniscale

1. It is recommended that the miniscale be mounted on the back of the table with the encoder box mounted to the saddle. A miniscale guard (supplied with mill hardware kits) is then mounted over the miniscale for extra protection.
2. Move the table fully to one end of its travel and lock it in that position. See Figure 6. Determine whether the miniscale will be mounted with the cable exiting to the left or to the right. Position the miniscale assembly against the back of the table so that the bottom longitudinal edge of the miniscale is flush with the lower edge of the table. Position the miniscale so that it does not cover any drain holes which are located at the ends of some tables. Route cabling so that the miniscale guard will not snag it.
3. Transfer punch the two mounting holes (located on each end of the miniscale) to the table. Refer to Section II for drilling precautions. Drill/tap for 1/4-20 x 3/4 low head socket cap bolts and mount the miniscale.

### HELPFUL HINTS

The miniscale can be easily positioned by resting it on two mag-bases placed under the table.

Holes can be more accurately positioned as follows:

- Transfer punch, then drill/tap the first hole.
- Mount the miniscale with one bolt so that it will pivot.
- Level the miniscale then transfer punch and drill/tap the second hole.

Using a pencil to draw crosshairs at the punch mark makes it easier to see if the drill is centered.

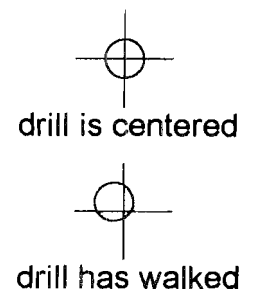

4. Indicate the spar surface (top) using a depth micrometer, dial indicator or calipers. Adjust the two miniscale ends so that the spar surface is parallel to the table travel within 0.005 inch over its entire travel.
5. Compensate for any bowing or sagging of the miniscale that may have been caused by inaccurate drilling.

DO NOT PROCEED BEFORE MAKING ANY NECESSARY CORRECTIONS.

6. Encoder Box Mounting

- a. Verify that the gap between the encoder box and the hardware mounting surface is less than 0.125 inch. See Figure 3. If it is not, a block must be fabricated to mount the encoder box.
- b. Transfer punch the two encoder box mounting holes to the saddle surface. Move the table so that holes can be drilled. Drill/tap for 8-32 x 3/4 socket cap screws.
- c. Return the table to its end of travel position. Insert and adjust the 4 encoder box set screws (5-40) until they just touch the mounting surface. Improper adjustment can force the encoder box out of its calibrated position and may cause erratic miniscale performance and damage.
- d. Mount the encoder box with the two 8-32 x 3/4 socket cap screws. Do not overtighten the encoder box mounting screws.
- e. Release the encoder box from the shipping bracket by removing the 10-32 x 3/8 pan head screw. The alignment bracket may be left on the miniscale or replaced with the end cap provided in the hardware kit.

NOTE

Save the alignment bracket for future use (Machine cleaning, service, etc.).

- f. Release the table lock and move the X axis table to its two extreme positions while monitoring the encoder box travel.

VERIFY THAT THE MINISCALE CANNOT BE OVERTRAVELED. See Figure 5.

7. Position the miniscale guard over the spar. Drill/tap for 8-32 x 3/8 pan head screws.
8. Install a cable clamp on the table where the cable just exits under the miniscale guard. See Figure 6. After installing the miniscale guard, it may be necessary to bend it out to provide additional clearance for the cable. It is not advisable to exit the cable out the end of the guard since during travel it may catch and pull the cable from the encoder box.
9. Install the "O" ring in the groove of the guard and mount the miniscale guard using the 8-32 x 3/8 pan head screws.
10. Route and secure the cables to the display. Ensure that the cables are not hanging loose to be caught on any part of the machine during operation.

NOTE

Do not run miniscale cables parallel with power wires. Induced noise may cause the display to miscount. Maintain a minimum of 6 inches between cables and cross at right angles.

## V. MILL - Y AXIS MINISCALE INSTALLATION

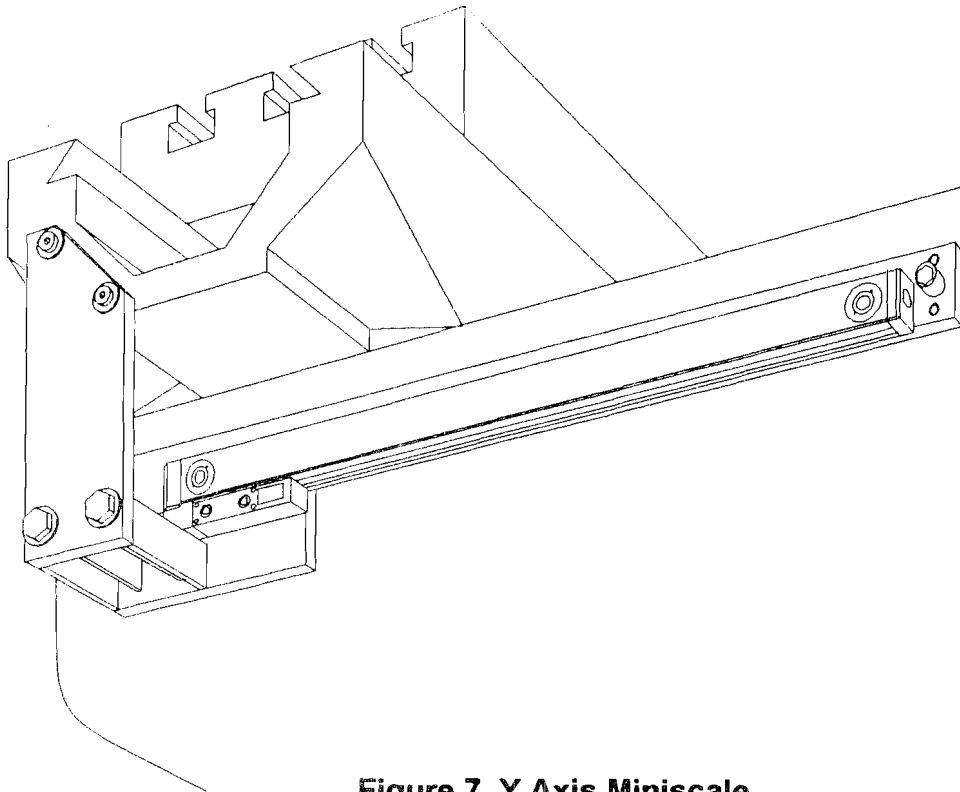

**Figure 7. Y Axis Miniscale**

1. It is recommended that the miniscale be mounted on the right side of the mill knee as viewed from the front. See Figure 7. Due to mill variations and specific applications it may be necessary to mount the miniscale on the left side. In most cases, the miniscale is best mounted with the encoder box (as it is locked to the alignment bracket) closest to the front of the mill.
2. Bridgeport mills have holes pre-drilled for backplate mounting. The Bridgeport hardware kit (515-M-BP) comes with a backplate that mounts directly to these mills. Other mills may also have these pre-drilled holes. Most imported Bridgeport style mills do not have these holes and they will have to be drilled into the mill for mounting. Hardware kits for these Bridgeport copy mills have a backplate with set leveling screws (515-M-BPC). Bridgeport backplates use shim washers between the backplate and the mill for leveling if necessary.
3. Lagun and some imported mills require a slotted "D" bracket for encoder box mounting to the saddle instead of the Bridgeport style hardware. This hardware (515-M-L/LC) may be mounted on either the rear or the front of the saddle depending on which is best for a particular application. The hardware drawing for these mills shows the slotted "D" bracket mounted to the rear of the saddle. Backplates in these hardware kits come with set leveling screws.

4. Attach the miniscale to the backplate. Do not tighten as adjustment will be needed when indicating. Be sure that the miniscale's alignment bracket will clear the backplate mounting holes. If it does not, remove the miniscale, and flip the backplate over and remount the miniscale. Mounting holes are offset to allow room for the alignment bracket.
5. With the hardware bracketry pre-assembled, hold it up to the mill to determine the mounting locations. Bridgeport backplates may be mounted to the pre-drilled holes. After locating the mounting area, mark both ends using the ways as a reference with a precision instrument, such as calipers. Drill/tap for 5/16-18 x 1-7/8 socket cap bolts. Mount the backplate (with the miniscale attached) to the mill. Verify that the encoder box bracket and the rest of the bracketry will mount to the encoder box. Adjust the backplate for parallelism using the leveling screws (or washer/shim for Bridgeport hardware) as necessary.

**SETSCREWS MUST BE PROPERLY ADJUSTED. IMPROPER ADJUSTMENT MAY CAUSE WARPING OR TWISTING OF THE BACKPLATE.**

6. Indicate the spar surface (top) with respect to the ways using a depth micrometer, dial indicator or calipers. Adjust the two miniscale ends so that the spar surface is parallel to the table travel within 0.005 inch over its entire travel. Use the ways as a reference. Indicate the miniscale face housing surface from end to end to within 0.005 inch over its entire travel. Adjust the backplate and/or miniscale using the leveling screws (or washer/shim for Bridgeport hardware) as necessary.
7. Move the table fully to its end of travel closest to the operator (standing in front of the machine) and lock it into position. Align the pre-assembled encoder box bracket to the miniscale's encoder box and to the area on the saddle where the bracket is to be mounted. Mark the saddle location and drill/tap for 1/4-20 x 3/4 socket cap bolts. Mount the bracket assembly
8. Encoder Box Mounting
  - a. Verify that the gap between the encoder box and the mounting bracket is less than 0.125 inch. See Figure 2. If it is not, adjust the backplate or modify the hardware as necessary.
  - b. Transfer punch the two encoder box mounting holes to the bracket. Drill/tap for 8-32 x 3/4 socket cap screws.
  - c. Insert and adjust the 4 encoder box set screws (5-40) until they just touch the mounting surface. Improper adjustment can force the encoder box out of its calibrated position and cause erratic miniscale performance and damage.
  - d. Mount the encoder box with the two 8-32 x 3/4 socket cap screws. Do not overtighten the encoder box mounting screws.
  - e. Release the encoder box from the alignment bracket by removing the 10-32 x 3/8 pan head screw. The alignment bracket may be left on the miniscale or replaced with the end cap provided in the hardware kit.

#### NOTE

Save the alignment bracket for future use (Machine cleaning, service, etc.).

- f. Release the table lock and move the Y axis table to its two extreme positions while monitoring the encoder box travel.

**VERIFY THAT THE MINISCALE CANNOT BE OVERTRAVELED. See Figure 5.**



9. No miniscale guard is provided for the mill Y axis since the miniscale is mounted underneath the saddle. However, an optional miniscale guard may be obtained by contacting your dealer or the factory.
10. Route and secure the cables to the display. Ensure that the cables are not hanging loose to be caught on any part of the machine during operation.

#### NOTE

Do not run miniscale cables parallel with power wires. Induced noise may cause the display to miscount. Maintain a minimum of 6 inches between cables and cross at right angles.

## **VI. MILL - QUILL MINISCALE INSTALLATION**

The hardware provided in the quill kit is designed to be used with Bridgeport style mills. A ball and cylinder gadget is used to mount the encoder box as shown in the hardware drawing. This may not work for all mills since quill feeds vary. Modification and/or fabrication of hardware may be necessary.

## **VII. MILL - KNEE MINISCALE INSTALLATION**

Where miniscales are used, the guidelines for installation are the same as for the Y axis. It is suggested that the miniscale be mounted with the encoder box facing to the back of the mill. A miniscale guard should also be placed over the unit after installation is completed. The knee hardware kit is designed to universally fit most mills. Some modification and/or fabrication of hardware will be required by the installer.

## **VIII. LATHE MINISCALE INSTALLATION**

Installation guidelines are the same for lathe miniscales. Follow the lathe hardware drawing for installation of the lathe miniscales and encoder box guards. Custom backplate fabrication may be required for some lathes. Lathe miniscales are mounted on the side of the carriage farthest from the chuck. Use X axis instruction guidelines for miniscales mounted directly to the table. Use Y axis instruction guidelines where miniscales are mounted on a backplate and attached to the bed travel. Miniscales mounted on the compound (Z axis) follow normal miniscale installation procedures.

## **IX. DISPLAY INSTALLATION**

1. With the miniscales installed and the cables routed, the display is now ready to be installed. Refer to the applicable display manual for display installation
2. Connect the miniscale's connectors to the display and screw them in place. Verify that the miniscale is connected to the correct axis on the digital readout.