

Prospector

Digital Readout System

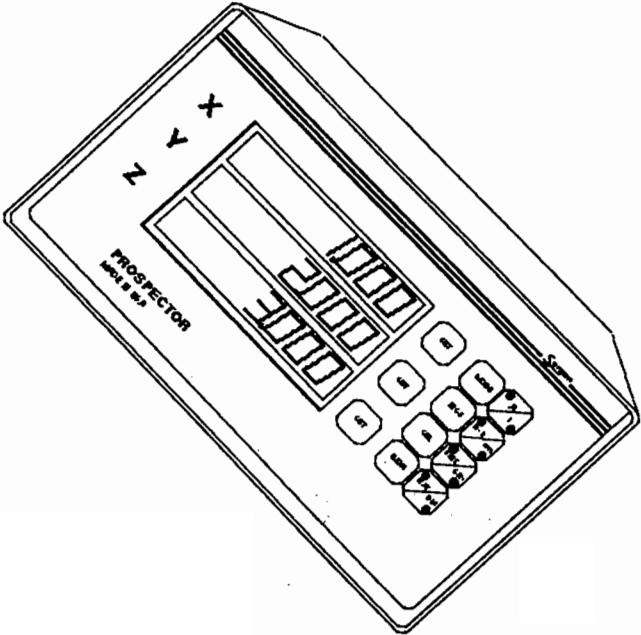

INSTRUCTIONS MANUAL



Table of Contents

Features	1
Quick Reference Flow Chart	3
Installation	5
AC Ground	7
AC Power Connection	7
Power Up	8
Entering Numerical Data	10
1. SEL+INCR buttons	11
2. Table Movements	12
Setup Screens	13
1. Scale Resolutions	13
2. Scale Directions	15
3. Diameter/Radius Selections	16
Cartesian and Polar Coordinate Systems	17
Clear All Functions	19
Resetting Absolute Coordinates	21
Normal Mode	22
1. Dimension Preset	23
2. Center Calculation	24
3. Dimension Recall	25
Program Mode	26
Programming a Bolt-Hole Pattern	27
Programming a Line-Hole Pattern	30
Run Mode	34
Running a Bolt-Hole Pattern	35
Running a Line-Hole Pattern	38
On-Line Help	42
Machine Error Compensation (MEC)	43
Viewing the MEC Factor	43
Clearing the MEC Factor	44
Calibrating MEC	44

Sargon Industries, Inc.
9400 Lurline Ave., Unit D
Chatsworth, CA 91311
USA

818 882-6904

Rel 111192-LD-1.21

Features

Congratulations on your purchase of the Sargon Prospector Digital Readout System. The Prospector offers many advanced features that go beyond basic DRO functions. Foremost among these is the ability to run Bolt-Hole and Line-Hole programs which considerably simplify performing such operations (see features shown below):

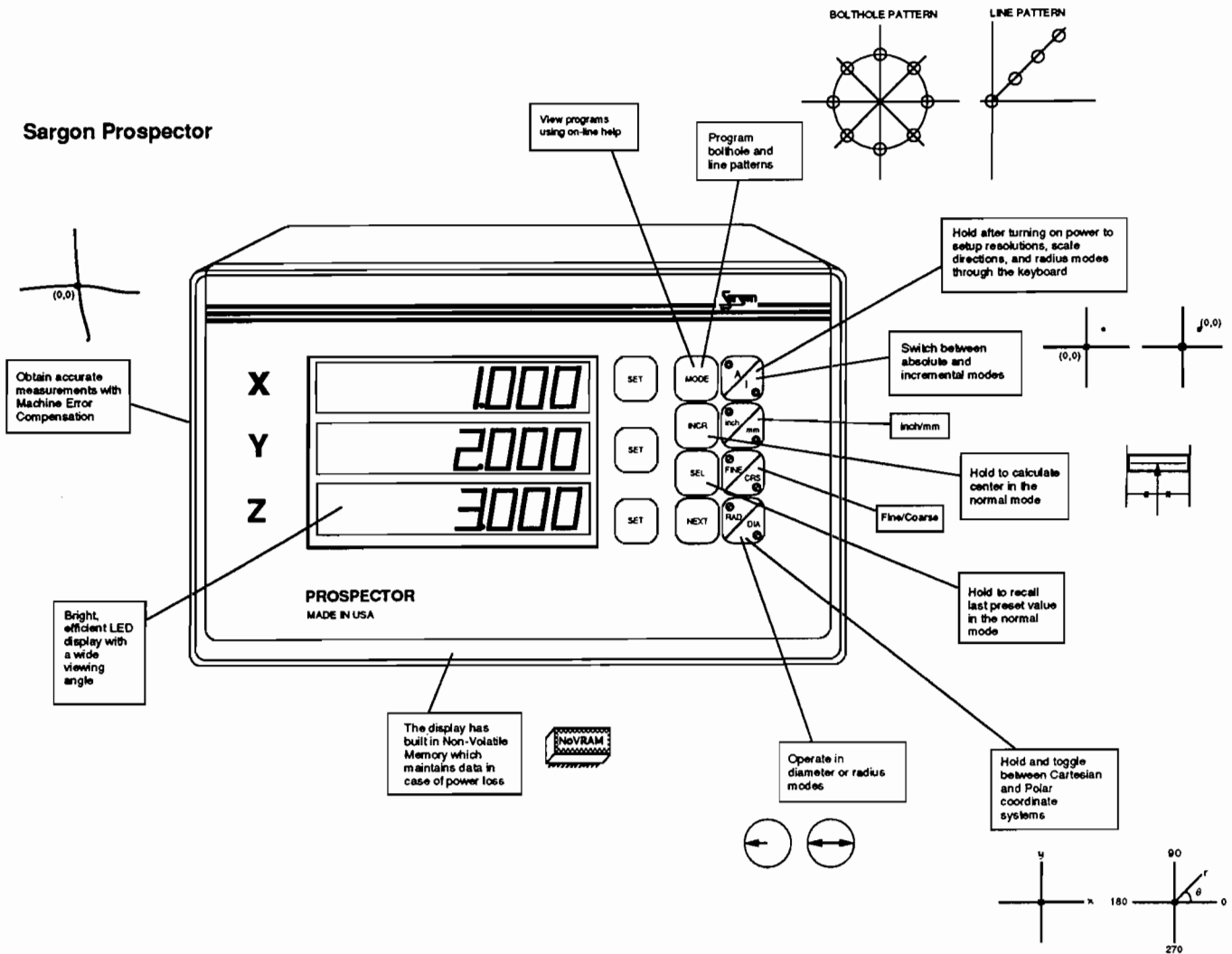

Warning: Use extreme caution!

Hazardous voltages!

All required electrical work should be performed by a qualified electrician.

**Mount the display arm a minimum of 6 inches (16 cm) away from any
motors.**

Quick Reference Flow Chart

Please note that to change modes at any point, press the MODE button. To advance through the functions, press NEXT, as shown in the Flow Chart.

The Prospector has the following modes:

1. Normal (RETURN TO NOR)
2. Program (Start of Prog)
3. Run (Start of Run)
4. On Line Help
5. Clear All
6. RS232* (optional)

The Prospector stores the last bolt-hole and a line-hole program that has been entered into its non-volatile memory. It is possible to run the stored programs in any sequence and as many times as you wish.

See the following page...

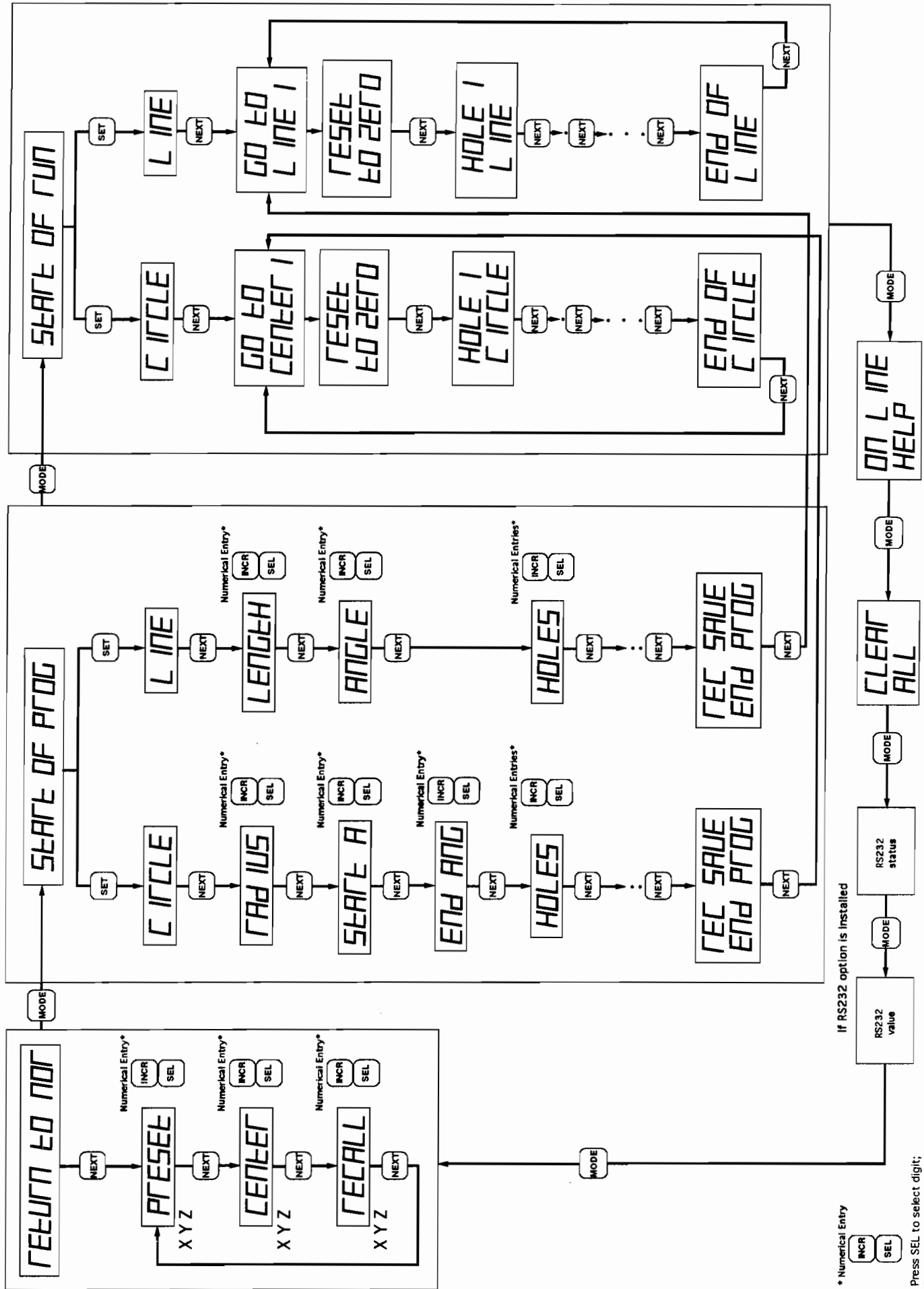

Quick Reference Flow Chart

* Numerical Entry



Press SEL to select digit;
Press INCR to increment digit

Installation

Display

Remove the large "eye-bolt" located on top of the milling machine column (see Figure 1). Mount the arm onto the machine and the display onto the arm with the 5/16-18 bolt provided in the Sargon hardware kit (see Figure 1).

Should you wish to mount the display under the arm, open the display and reverse the top and bottom halves of the case (see Figure 2). Bolt the display under the arm using the 5/16-18 bolt provided in the Sargon hardware kit (see Figure 3).

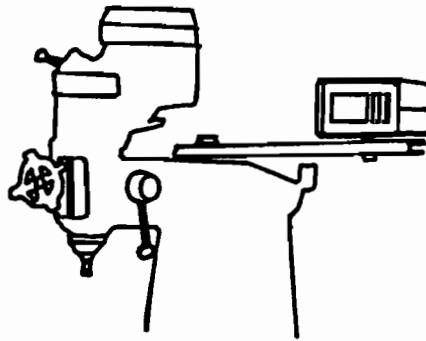

Figure 1: Display on a milling machine (normal configuration)

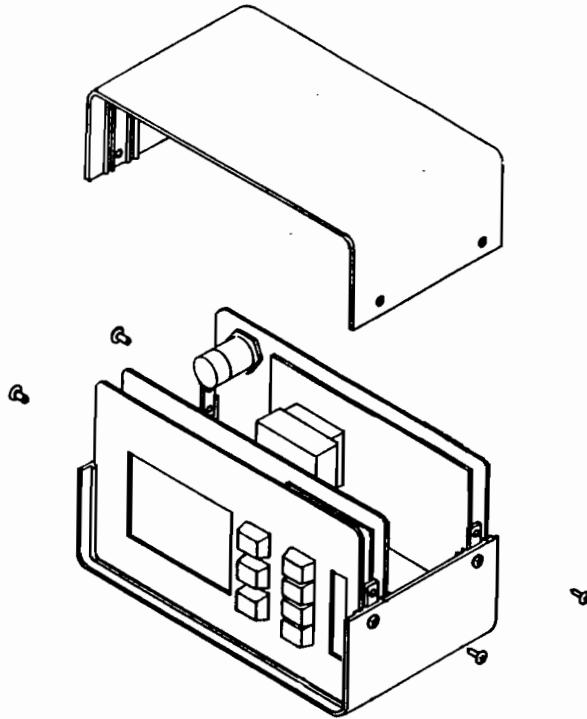

Figure 2: Opening of the display to reverse case halves

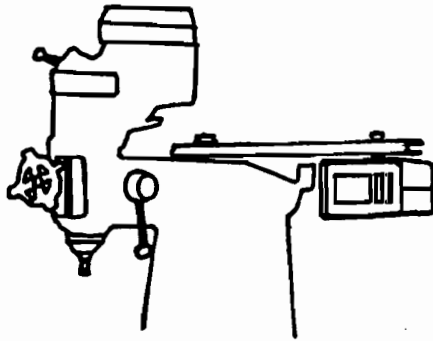

Figure 3: Display on a milling machine (reverse configuration)

AC Ground

The AC socket used should be a three prong grounded outlet (as per Article 250 of the US National Electrical Code). If a three prong outlet is not available, use a grounded adapter and verify that the adapter is grounded.

Note: Verify that the machine is grounded; if it is not, a ground must be installed.

Install a 14 AWG stranded wire (customer provided) from the ground lug on the back of the Prospector to the machine power ground connection. If this is not possible, locate an alternate place on the machine and drill+tap. Use star or split washers to secure the ground wire to provide an adequate connection. Use an approved anti-oxidation compound on the connection where the paint was scraped.

AC Power Connection

Do not connect the Prospector to an outlet which is also used to power a *machine* ; use a separate outlet. If an outlet is not available, one should be installed near the display mounting location.

The AC power outlet should be of the same voltage indicated on the identification/serial number on the back of the display.

Use the power cord supplied. Do not modify the power cord.

Connect and secure the scale cable connectors to the display. Using tie-wraps, secure the scale cables and *dress* any excess slack. Do not wrap any AC power lines together with the scale cables. Maintain a minimum of 6 inches (16 cm) from AC lines and cross them at right angles.

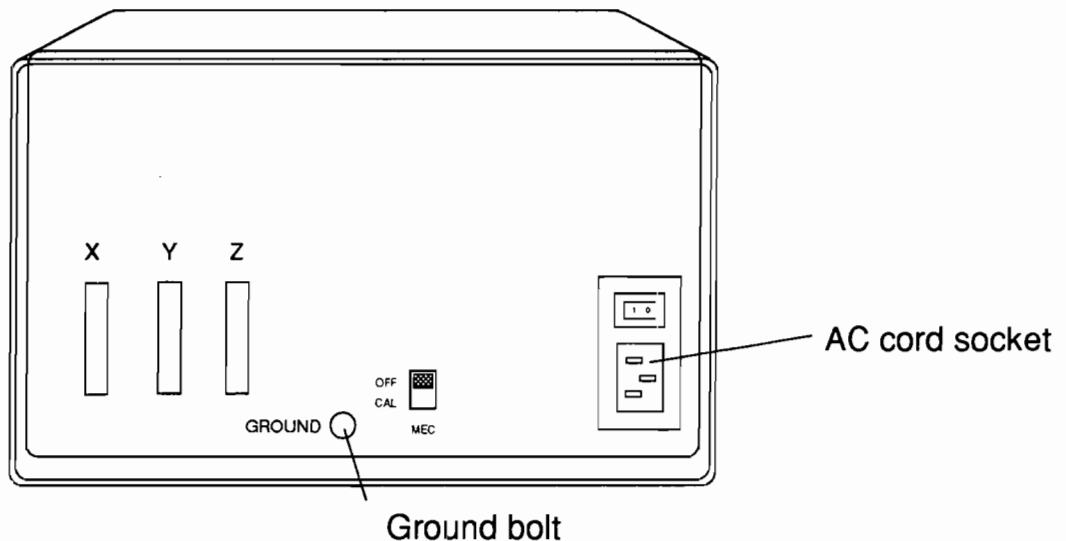

Figure 4: Power cord, AC outlets, ground bolt

Power Up

Turn the unit on using the power switch located on the back of the display (see Figures 5 and 6). The DRO will display and flash "8.8.8.8.8.8.8."

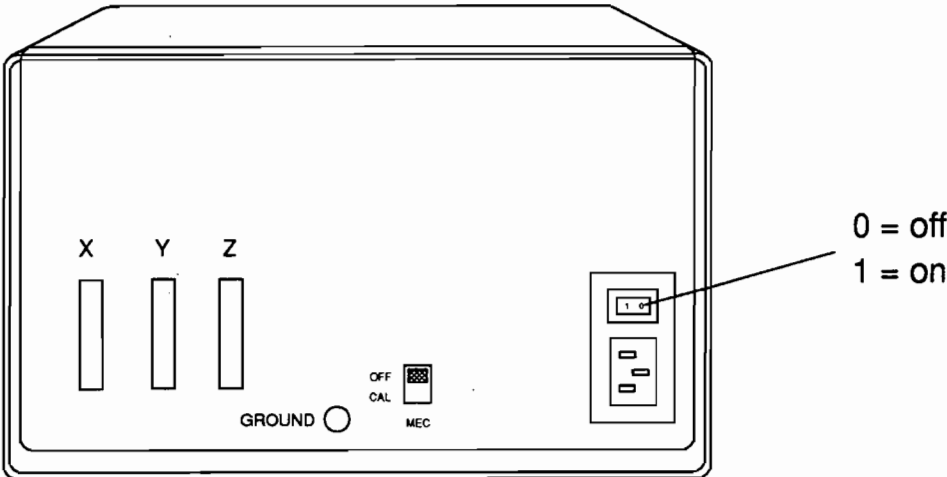

Figure 5: ON/OFF switch

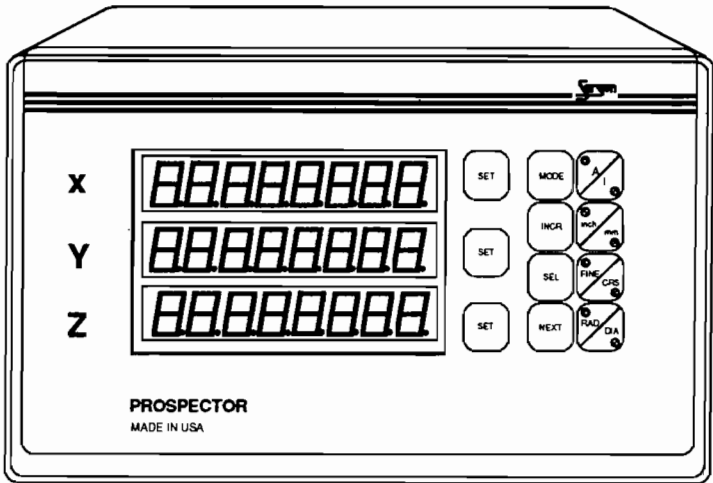

Figure 6: Flashing 8's (initial display)

The flashing 8's, will remain until you press a button. If you press and hold the A/I button, the display will enter the Setup Screens (see Setup Screens). If you press any other key, the display will enter the Normal Mode (see Normal Mode).

Entering Numerical Data

Instead of using a *numeric* key pad, the Prospector employs two alternative methods for entering numerical data:

1. SEL and INCR Buttons
2. Table Movements

See the following page...

1. SEL+INCR Buttons

Press SEL to select a digit to edit. Press INCR to increment the selected digit, or press and hold INCR to increment the digit continuously (see Figure 7).

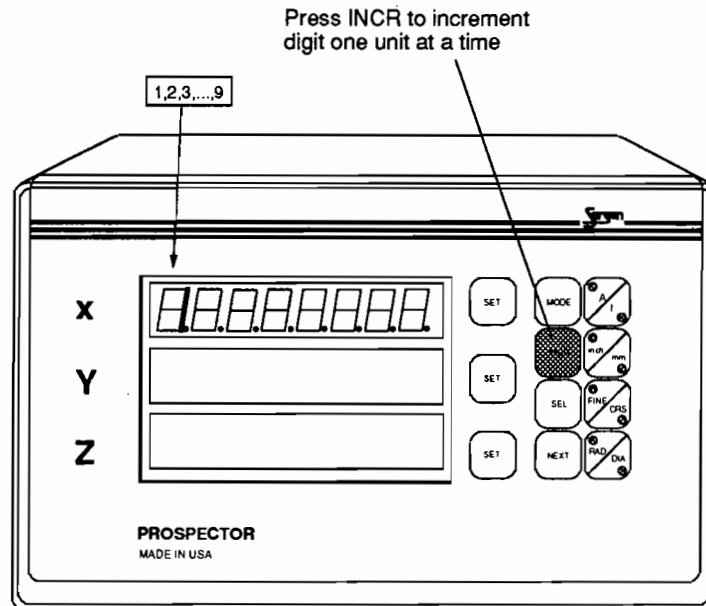
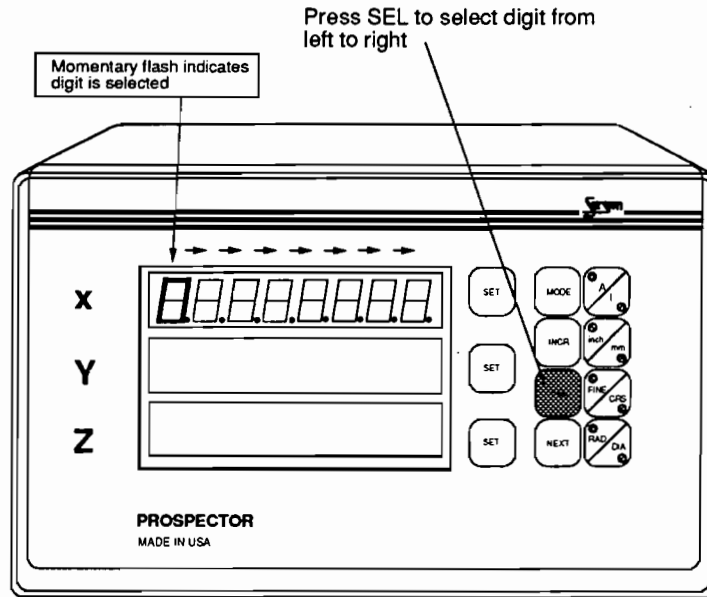

Figure 7: Using SEL/INCR buttons

2. Table Movements

Simply move the table until desired numeric values are displayed on the appropriate axis(es) (see Figure 8).

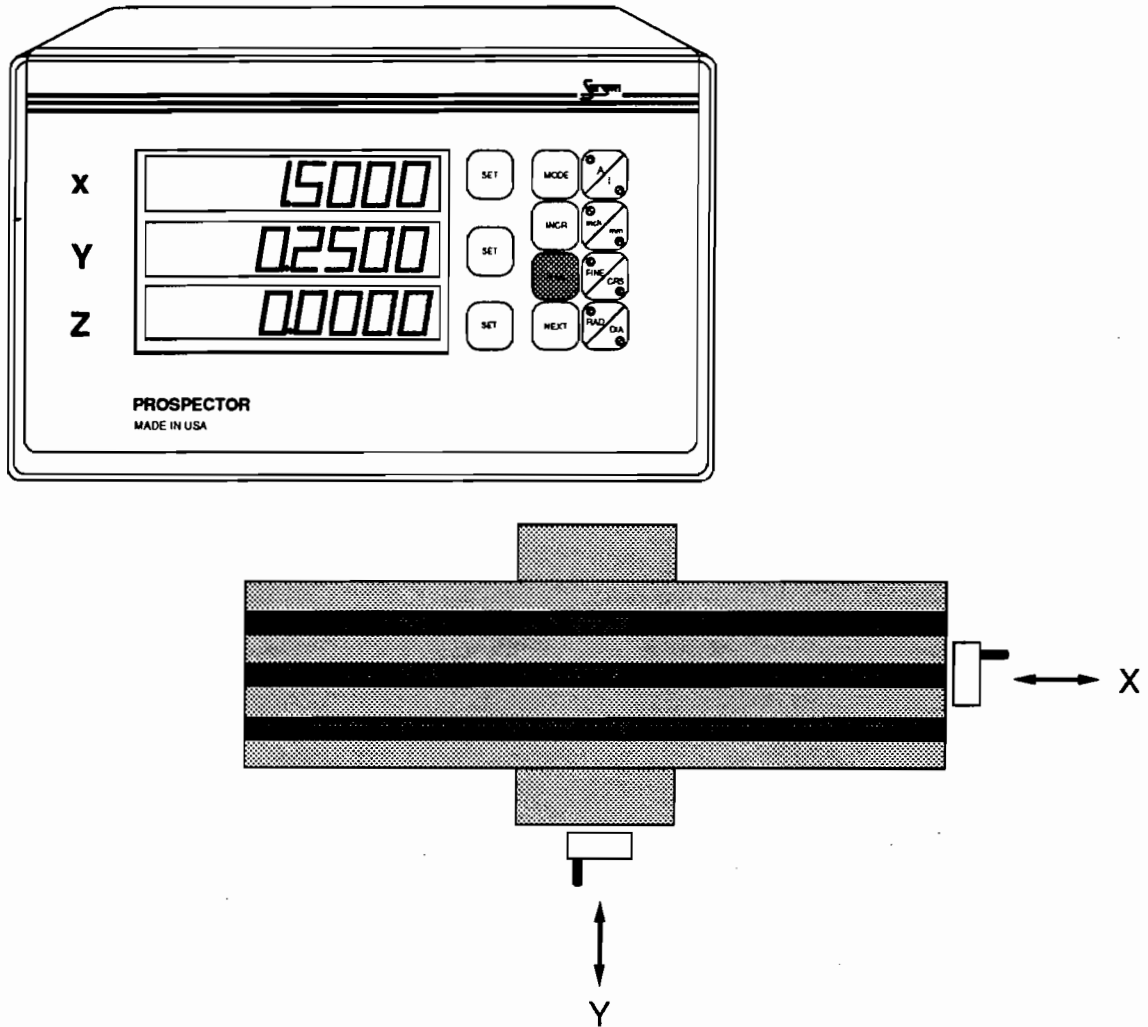

Figure 8: Numerical data entry by table movements

Setup Screens

After power up when the display is still flashing "8.8.8.8.8.8.8.", press and hold the A/I button to enter the Setup Screens (see Figure 9).

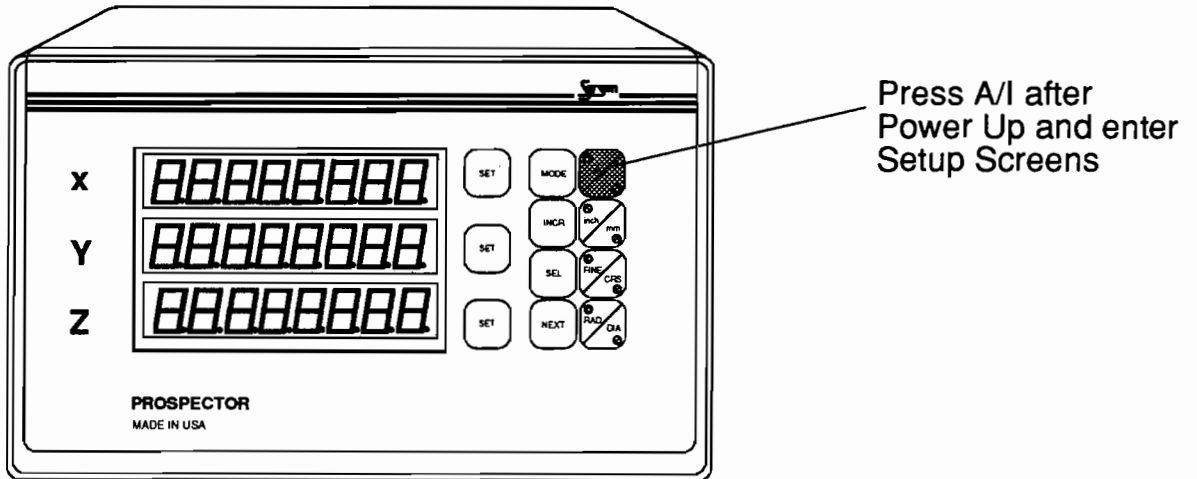

Figure 9: Entering Setup Screens

In the Setup Mode, there are 3 screens that enable you to select:

1. Scale Resolutions
2. Scale Directions (polarity)
3. Diameter/Radius Selections

1. Scale Resolutions

While in the Setup Mode, press NEXT until the DRO displays the following (see Figure 10):

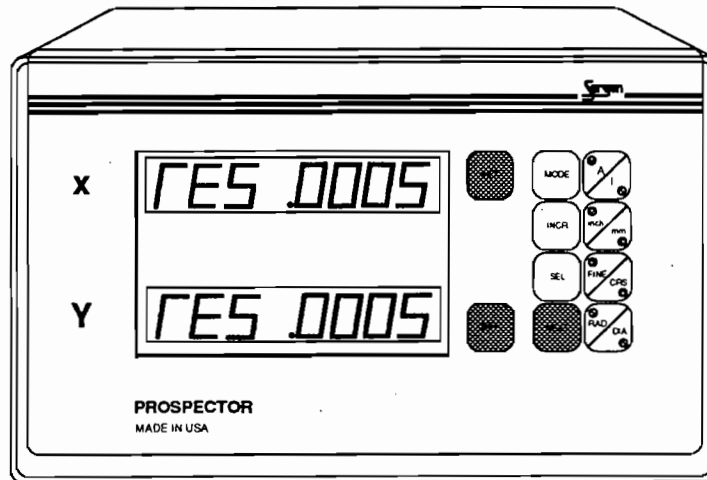

Figure 10: Scale Resolutions

Press SET to toggle through available scale resolutions. When the appropriate scale resolutions are displayed, press A/I to exit to Normal Mode or press NEXT to advance to the next Setup Screen. The last displayed value(s) and setting(s) will be saved automatically.

Note: The scales determine the system resolution, not the DRO. This screen allows the DRO resolutions to match the scale resolution for each axis.

2. Scale Directions

While in the Setup Mode, press NEXT until the DRO displays the following (see Figure 11):

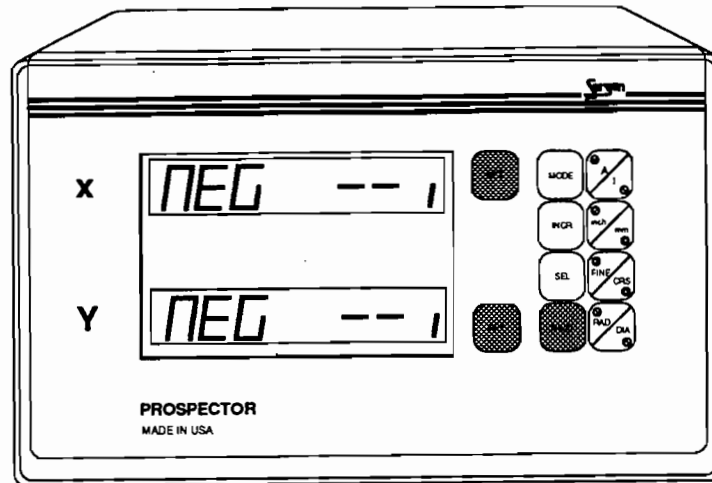

Figure 11: Scale Directions

Press SET to toggle between positive and negative scale directions. When the appropriate scale directions are displayed, press A/I to exit to Normal Mode or press NEXT to advance to the next Setup Screen. The last displayed directions will be saved automatically.

Note: Directions must be correct for angle functions to operate properly. Each axis is set independently.

3. Diameter/Radius Selections

While in the Setup Mode, press NEXT until the DRO displays the following (see Figure 12):

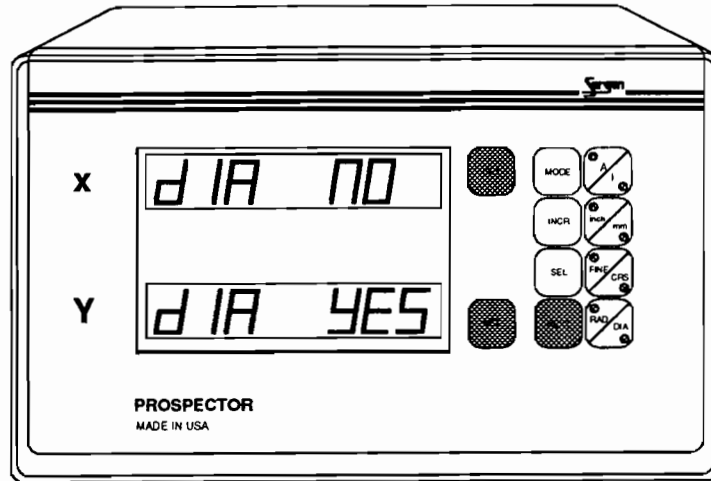

Figure 12: DIA/RAD

Press SET to toggle between radius and diameter settings (DIA NO = diameter disabled (radius), DIA YES = diameter enabled). When the desired settings are displayed, press A/I to exit to Normal Mode or press NEXT to advance to the next Setup Screen. The last displayed settings will be saved automatically.

Note: The RAD/DIA button will affect each axis for which this feature has been enabled.

Cartesian and Polar Coordinate Systems

The Prospector is capable of displaying in both Cartesian and Polar Coordinate Systems.

Press and hold the RAD/DIA button to toggle between the Cartesian and Polar modes (see Figures 13 and 14).

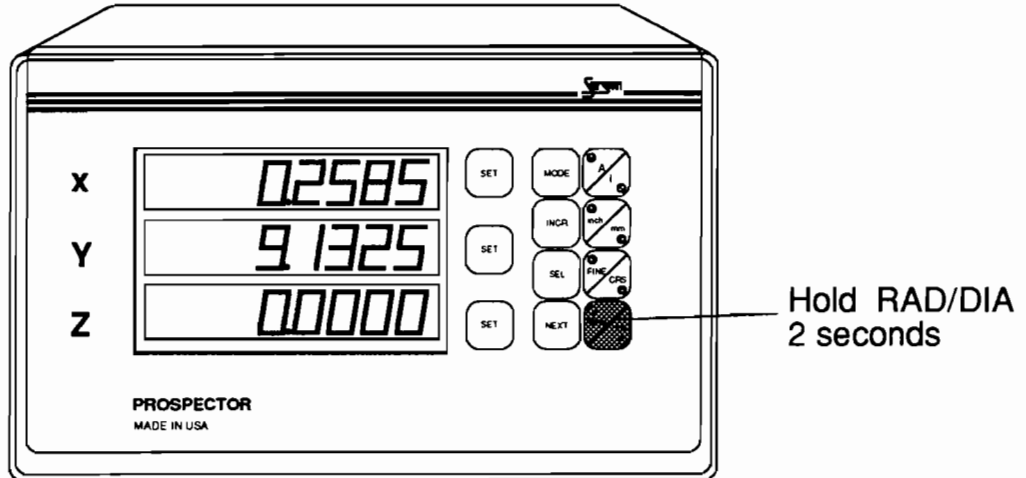

Cartesian

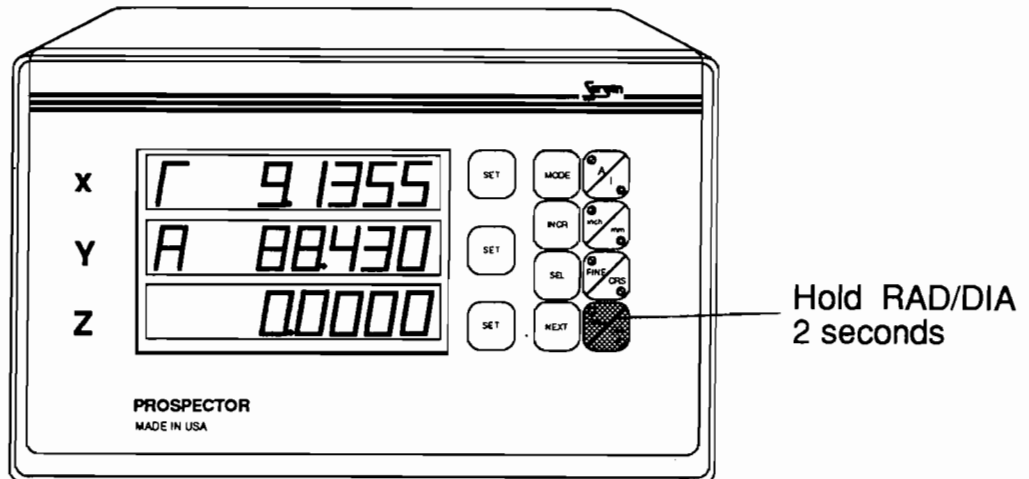

Polar

Figure 13: CART/POLAR

Cartesian

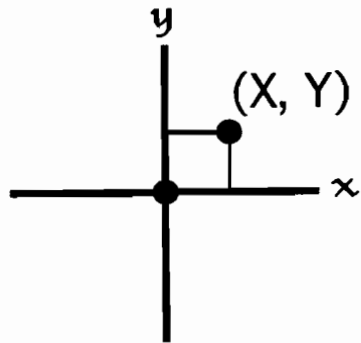

Polar

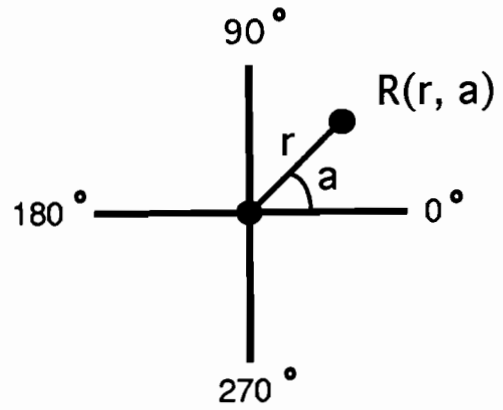

Figure 14: Comparison of Cartesian and Polar Systems

Clear All Function

To clear the display's memory, press MODE until the DRO displays CLEAR ALL (see Figure 15). Then press SEL. This function is useful in cases when conditions have caused data corruption resulting in malfunction.

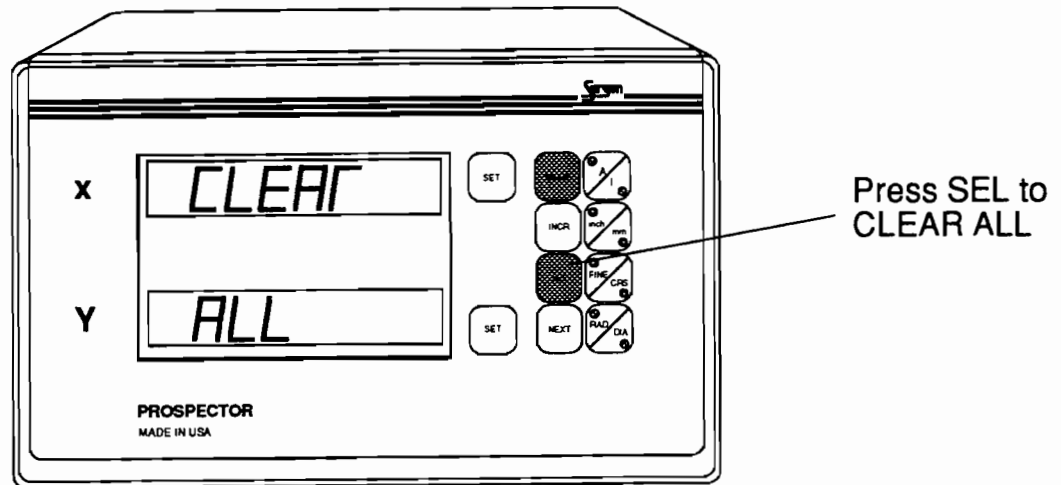

Figure 15: CLEAR ALL

Caution! This functions will cause the following:

1. Setup parameters will be set to default values: RES = 10 μm , SCALE DIRECTIONS = negative, X = RAD (shown as DIA NO), and Y = DIA (shown as DIA YES; see Figure 16).
2. Circle and Line programs will be erased and replaced by sample demo programs.
3. Position information will be lost.

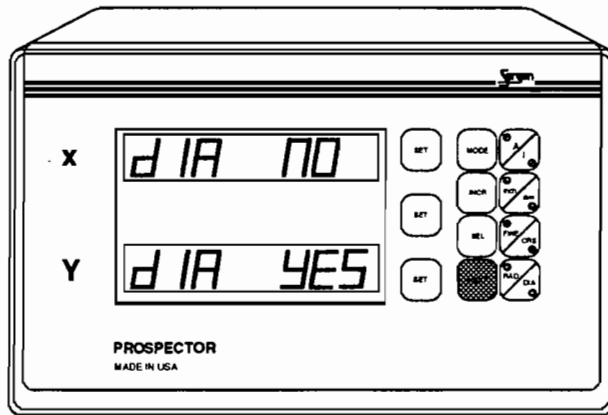
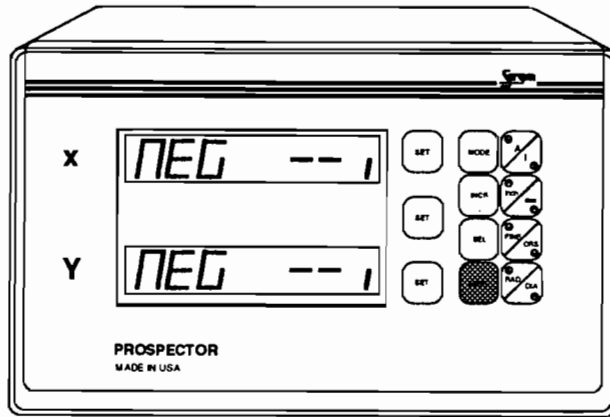
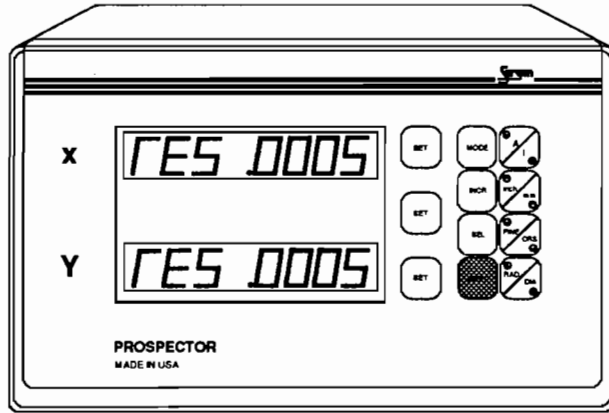

Figure 16: Default Setup Screens

Resetting the Absolute Coordinates

Using the A/I button, toggle to the Absolute Mode (A). Then press and hold the A/I button until the unit displays ZERO ABS (see Figure 17). At that point press the relevant SET button(s) to reset the corresponding absolute coordinate(s) to zero.

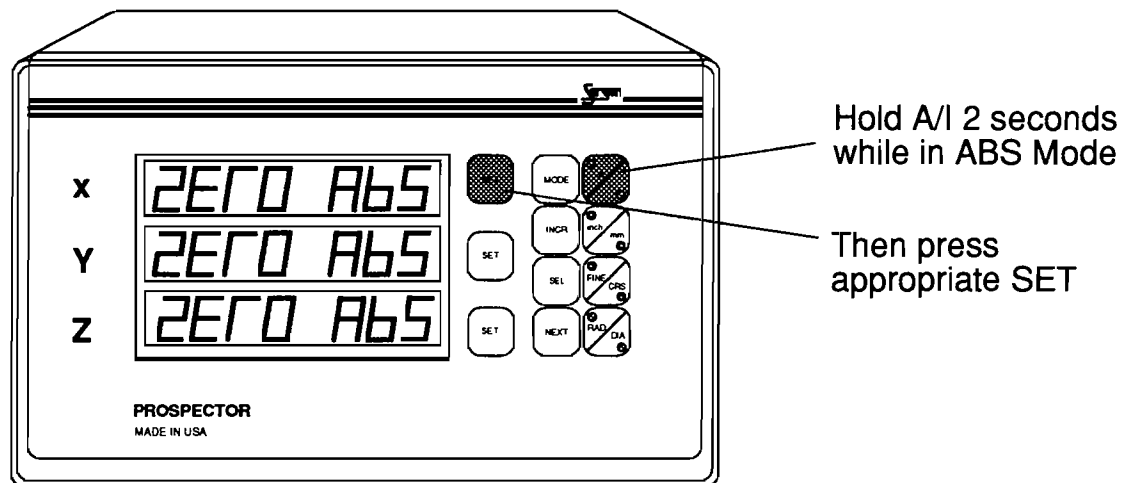

Figure 17: ZERO ABS

Normal Mode

This is the basic DRO mode where the unit displays the positions of the scales.

Press any key other than A/I after power up and the display will enter the Normal Mode. If you press and hold the A/I button, the display will enter the Setup Mode which you can then exit to Normal Mode by pressing any key.

To go to the Normal Mode when the unit is in another mode, press the MODE button until the unit displays RETURN TO NOR (see Figure 18).

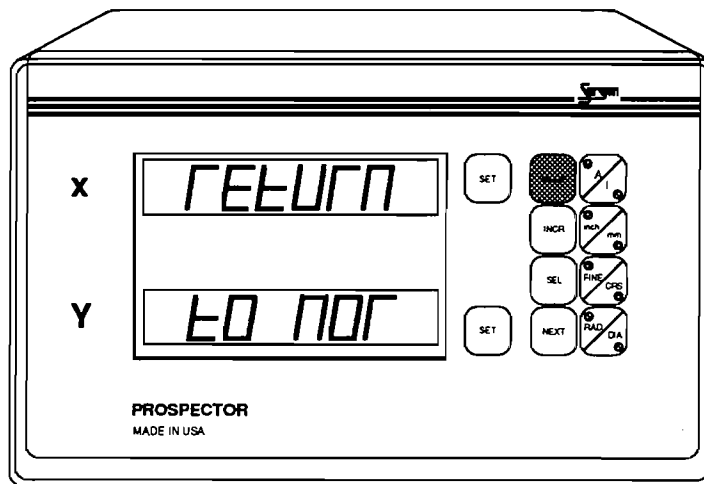

Figure 18: RETURN TO NOR (momentary)

In addition to the basic DRO function of displaying scale positions, the Prospector also performs the following functions while in the Normal Mode:

1. Dimension Preset
2. Center Calculation
3. Dimension Recall

1. Dimension Preset

While in the Normal Mode, press NEXT until PRESET is momentarily displayed, followed by a coordinate value (see Figure 19):

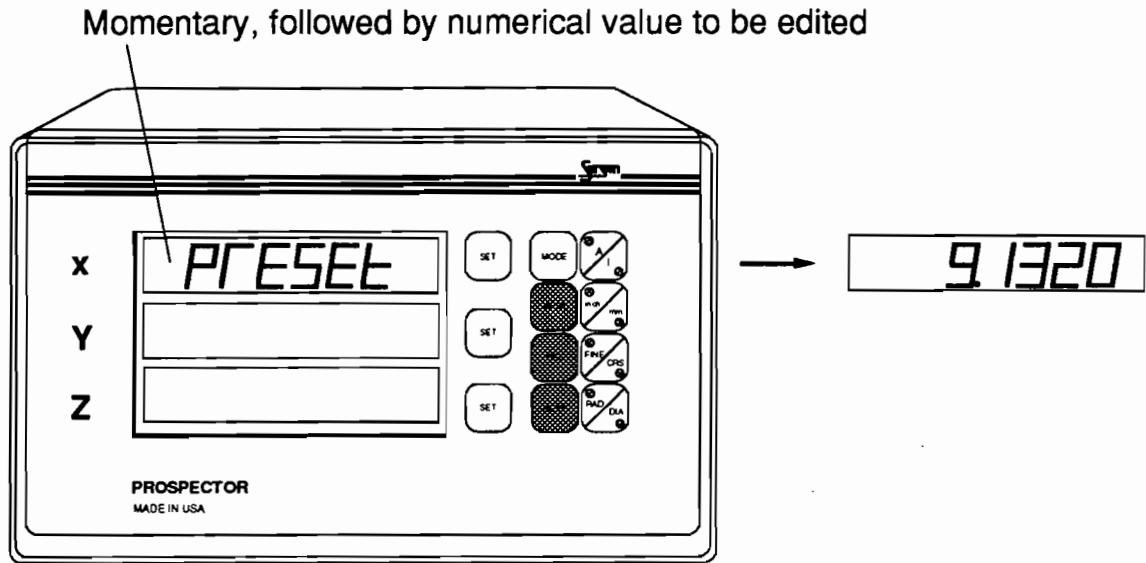

Figure 19: PRESET

Enter a desired preset value by using SEL and INCR buttons or table movements (see Entering Numerical Data).

2. Center Calculation

While in the Normal and Incremental Modes, press NEXT until CENTER is momentarily displayed on the desired axis, followed by a coordinate value (see Figure 20):

Momentary, followed by numerical value to be edited

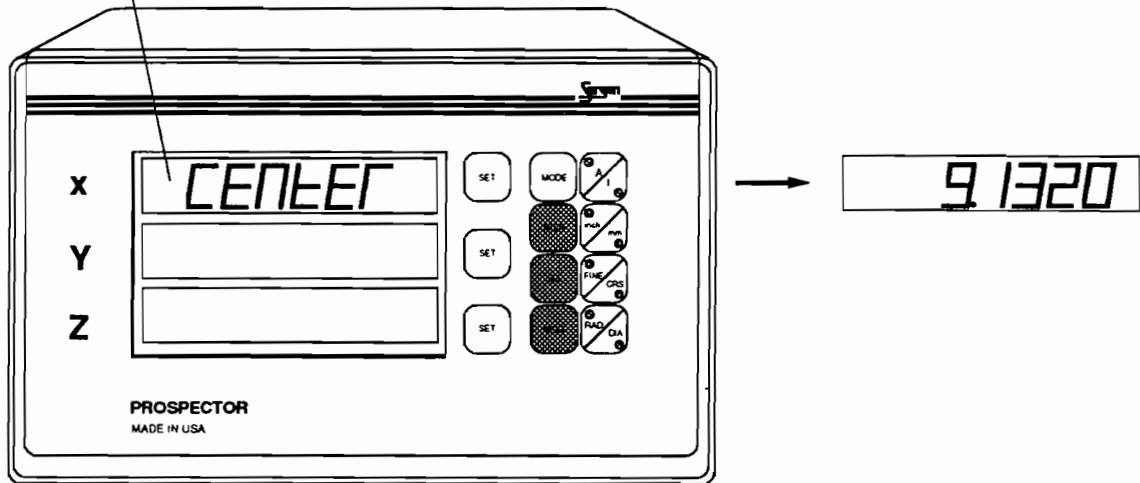

Figure 20: CENTER

Press and hold SEL for 2 seconds to divide the displayed dimension by 2 for the selected axis.

Program Mode

In this mode, you may enter Bolt-Hole or Line-Hole programs.

To enter the Program Mode, press MODE until the DRO displays START OF PROG (see Figure 22).

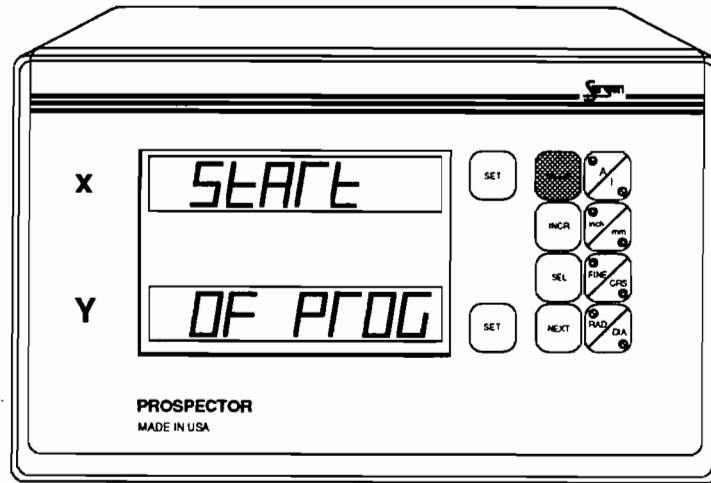

Figure 22: START OF PROG (momentary)

The Prospector will then display the words CIRCLE and LINE (see Figure 36). Press NEXT to default to CIRCLE or choose the program type you wish to run either by toggling between the two choices using the SEL button or by pressing the corresponding SET button. Press NEXT to continue.

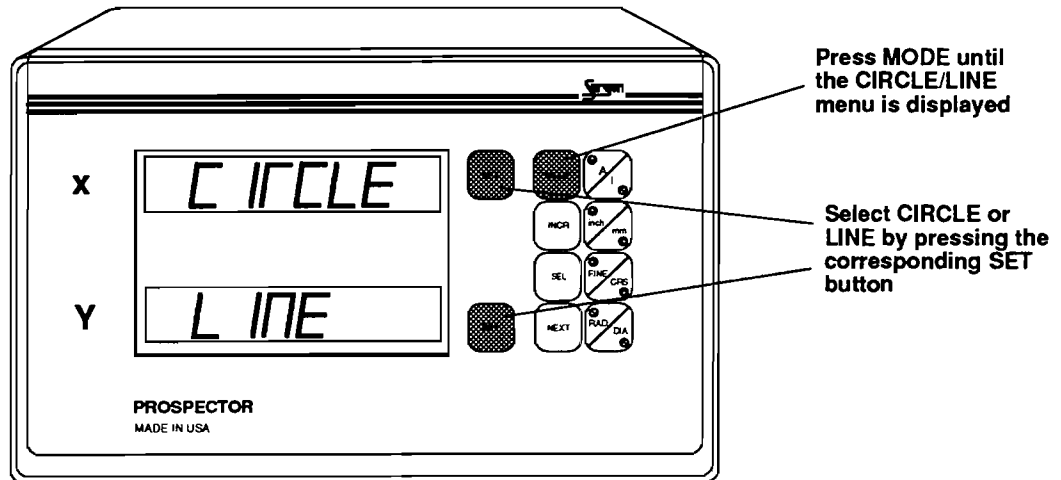

Figure 23: CIRCLE/LINE

Programming a Bolt-Hole Pattern

Choose CIRCLE in the Program Mode and the unit will request the size of the radius (see Figure 24).

Enter the radius using the SEL and INCR buttons or table movements (see Figure 24 and refer to Entering Numerical Data). Then press NEXT.

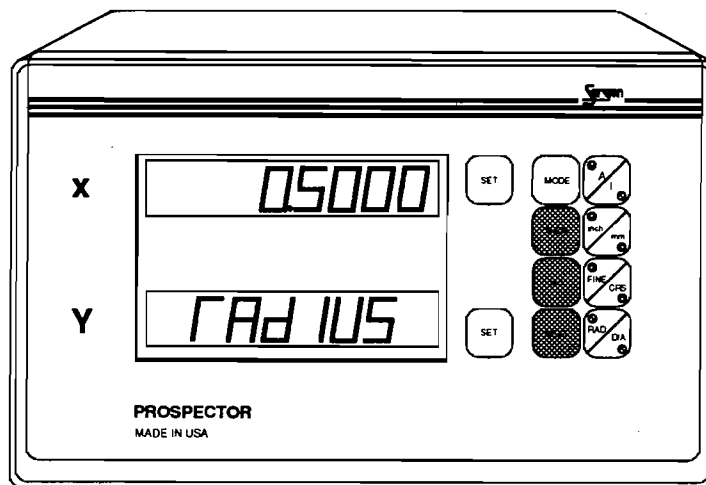

Figure 24: RADIUS

The Prospector will then request the starting angle (see Figure 25). Enter the angle and press NEXT.

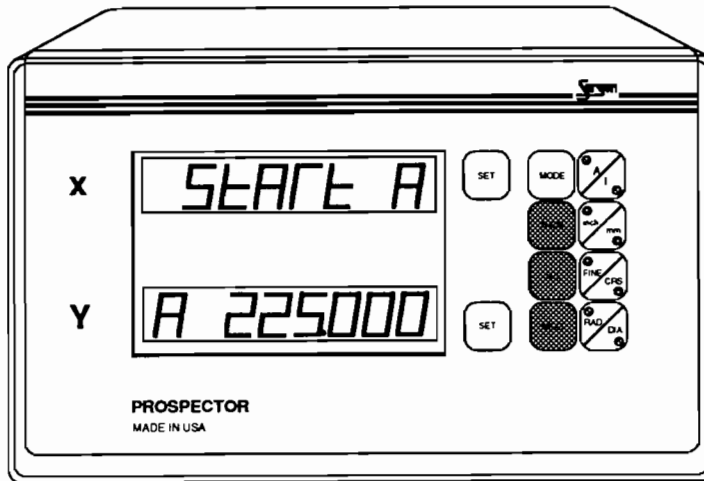

Figure 25: START ANGLE

The Prospector will request the ending angle (see Figure 26). Enter the angle and press NEXT.

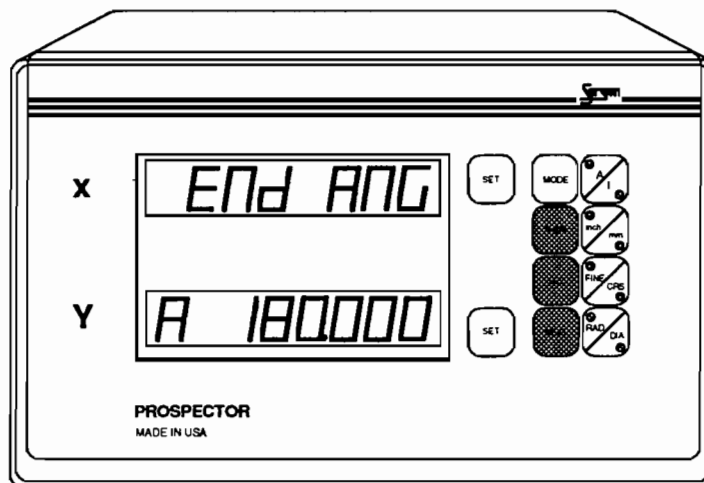

Figure 26: END A

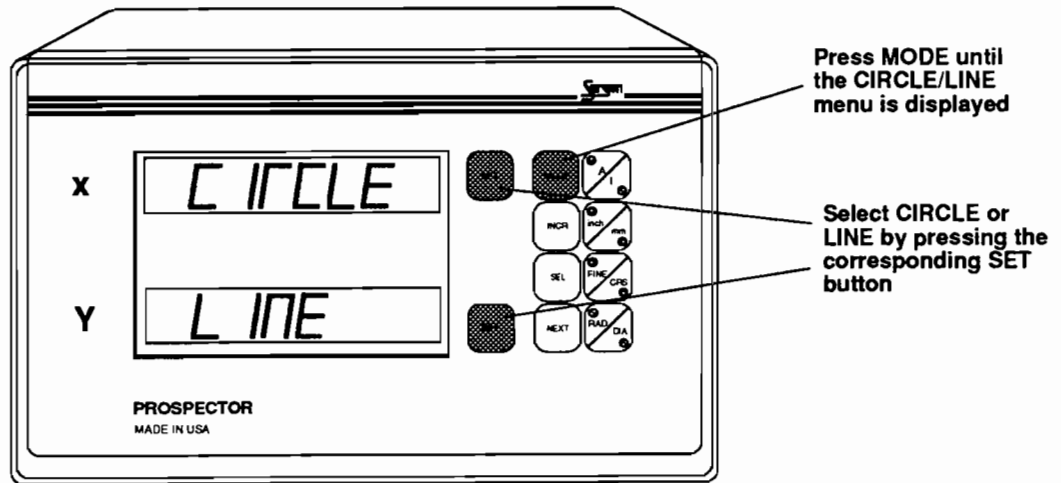

Figure 23: CIRCLE/LINE

Programming a Bolt-Hole Pattern

Choose CIRCLE in the Program Mode and the unit will request the size of the radius (see Figure 24).

Enter the radius using the SEL and INCR buttons or table movements (see Figure 24 and refer to Entering Numerical Data). Then press NEXT.

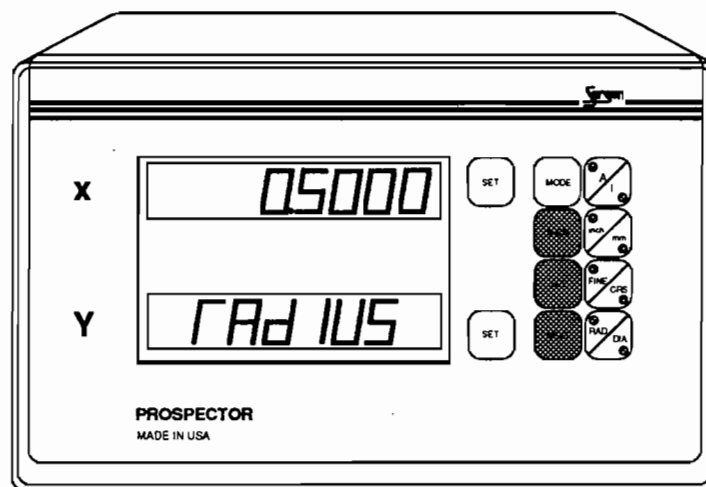

Figure 24: RADIUS

The Prospector will then request the starting angle (see Figure 25). Enter the angle and press NEXT.

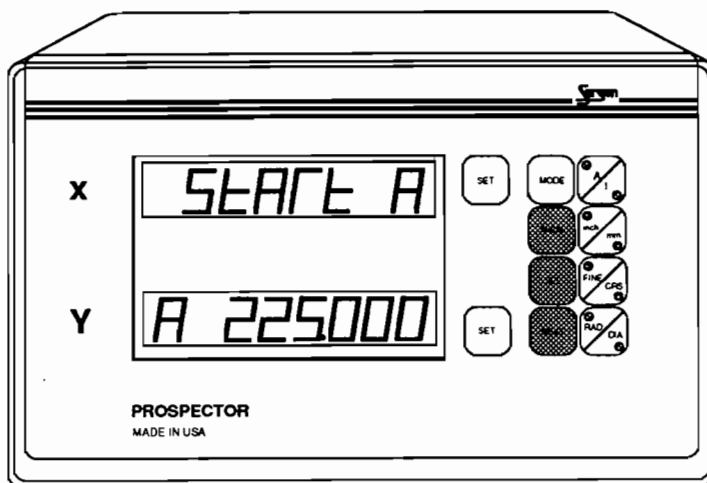

Figure 25: START ANGLE

The Prospector will request the ending angle (see Figure 26). Enter the angle and press NEXT.

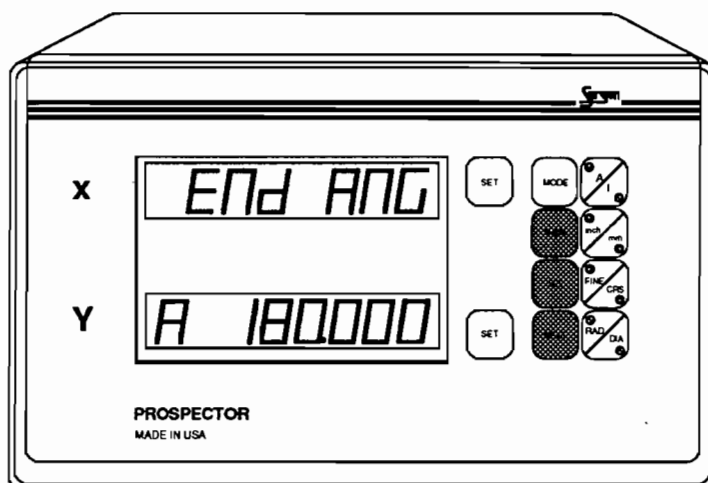

Figure 26: END A

Note: If the End Angle equals the Start Angle, holes will be spaced evenly around the circumference; the first hole will be determined by Start Angle (see Figure 27).

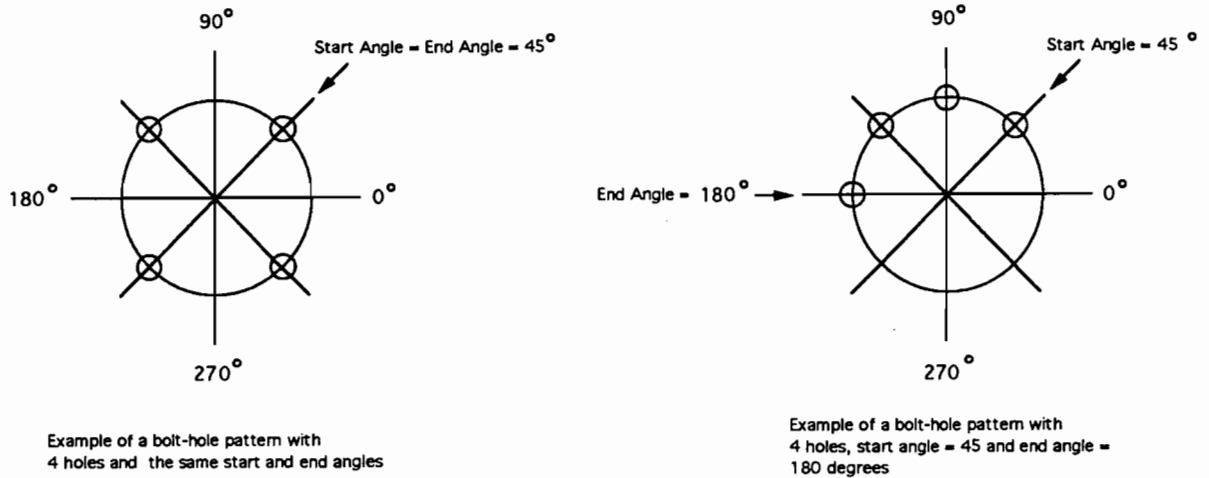

Figure 27: Start Angle and End Angle

Finally, the Prospector will request the number of holes. Enter the number of holes and press NEXT (see Figure 28).

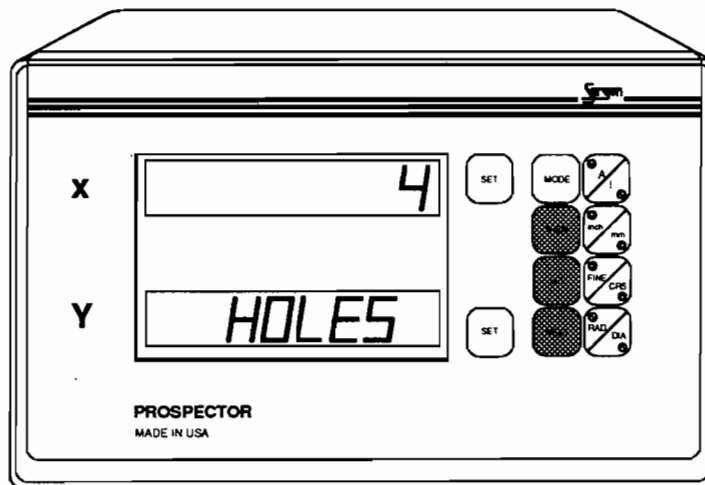

Figure 28: HOLES

The program is now complete and the unit displays the following (see Figure 29):

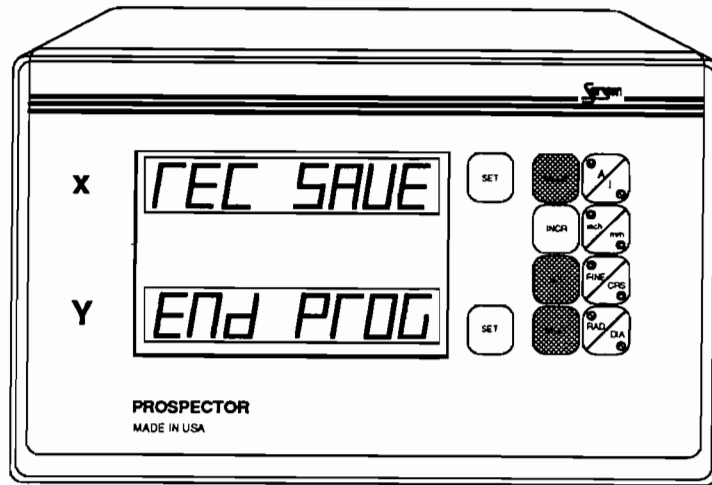

Figure 29: REC SAVE/END PROG

Press SEL, MODE, or NEXT and the program you have just entered will be saved (see Flow Chart). Pressing SEL or MODE buttons will take the DRO to the beginning of Run Mode, where you must choose between CIRCLE and LINE. Pressing NEXT will skip this selection process and will take the DRO to the first step of the program you have just entered (see Flow Chart and the Run Mode sections of this manual).

Programming a Line -Hole Pattern

Choose LINE in the Program Mode and the unit will request the length of the Line-Hole Pattern (see Figure 30).

The Prospector will then request the angle of the line with respect to the X axis (see Figure 32). Enter the angle and press NEXT.

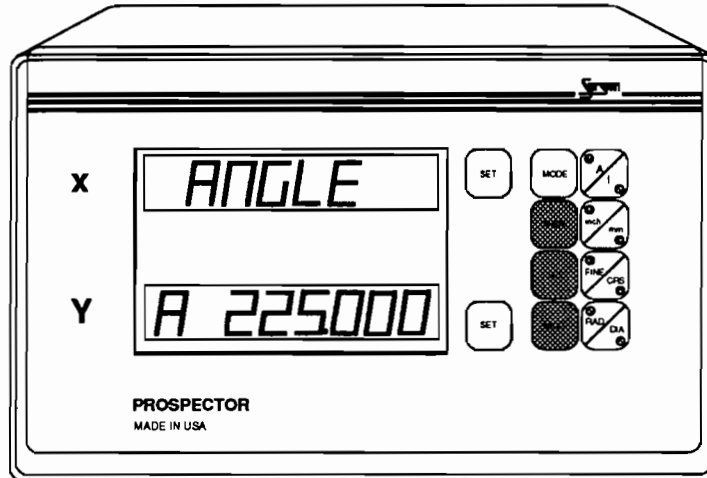

Figure 32: ANGLE

Finally, the Prospector requests the number of holes (see Figure 33). Enter the number of holes and press NEXT.

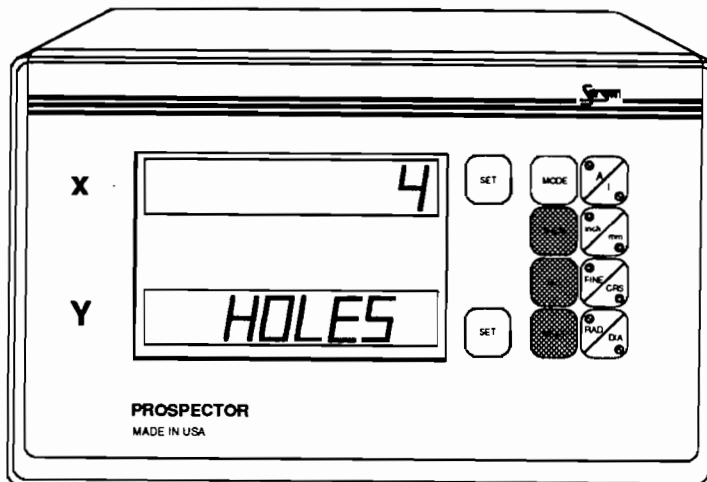

Figure 33: HOLES

The program is now complete and the unit displays the following words (see Figure 34):



Figure 34: REC SAVE/END PROG

Press SEL, MODE, or NEXT and the program you have just entered will be saved (see Flow Chart). Pressing SEL or MODE buttons will take the DRO to the beginning of Run Mode, where you must choose between CIRCLE and LINE. Pressing NEXT will skip this selection process and will take the DRO to the first step of the program you have just entered (see Flow Chart and the Run Mode sections of this manual).

Run Mode

If you have just entered a program and wish to *immediately* run it, you may simply press NEXT after you save the program. However, this will take the DRO to the beginning of the Run Mode, where you must choose between a CIRCLE and LINE program.

If you wish to run a program which you have previously entered and saved in the DRO, press MODE until the Prospector momentarily displays START OF RUN (see Figure 35).

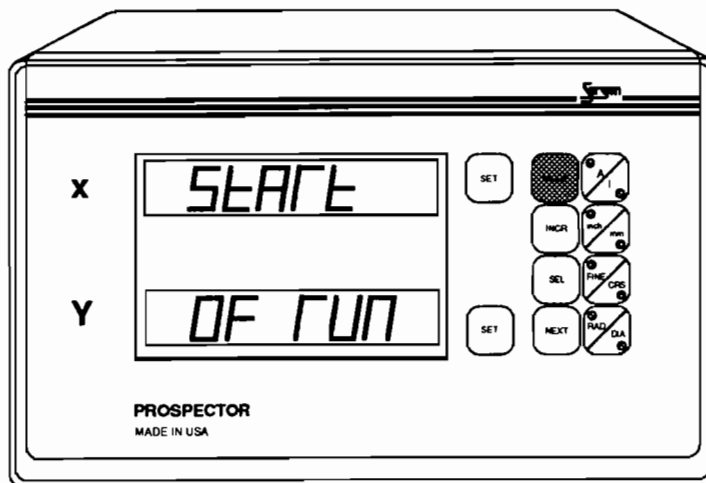

Figure 35: START OF RUN (momentary)

The Prospector will then display the words CIRCLE and LINE (see Figure 36). Press NEXT to default to CIRCLE or choose the program type you wish to run either by toggling between the two choices using the SEL button or by pressing the corresponding SET button. Press NEXT to continue.

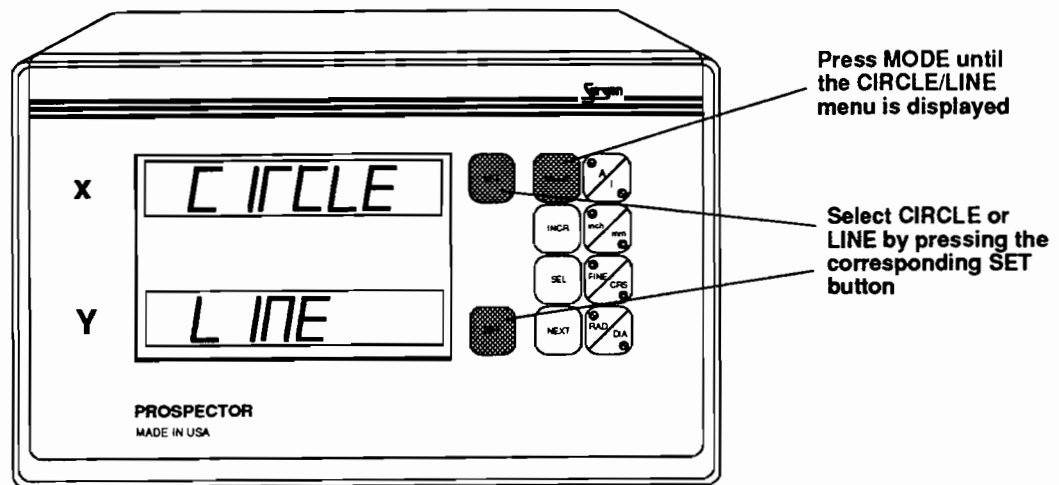

Figure 36: CIRCLE/LINE

Note: To exit Run Mode at any time, press MODE.

Running a Bolt-Hole Program

Choose CIRCLE in the Run Mode and the DRO will display the following screens (see Figures 37 and 38):

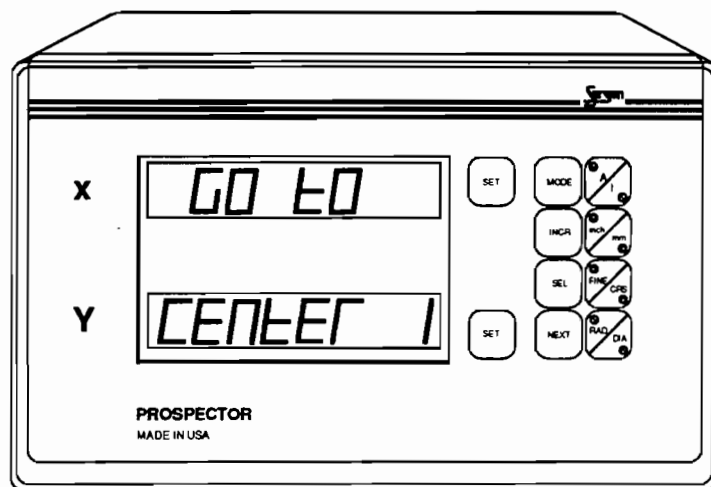

Figure 37: GO TO CENTER 1 (momentary)

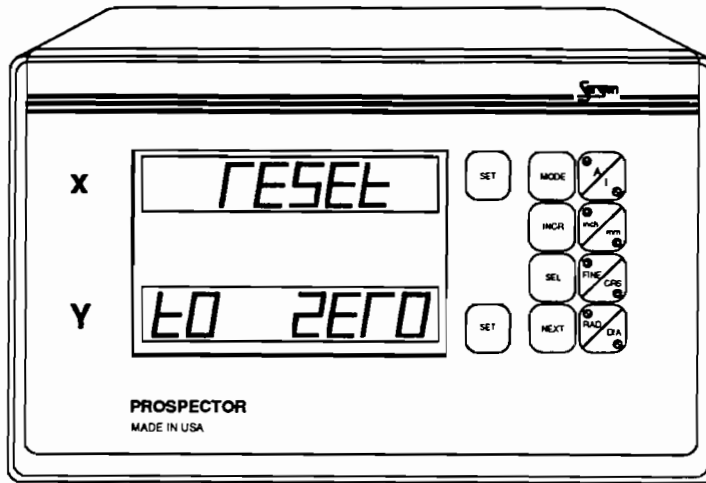

Figure 38: RESET TO ZERO (momentary)

In ABS Mode, move the table so that the spindle is pointing to the desired center. Change to INCR Mode and zero the axes by pressing the SET buttons.

The DRO will display the coordinates of HOLE 1 (see Figure 39).

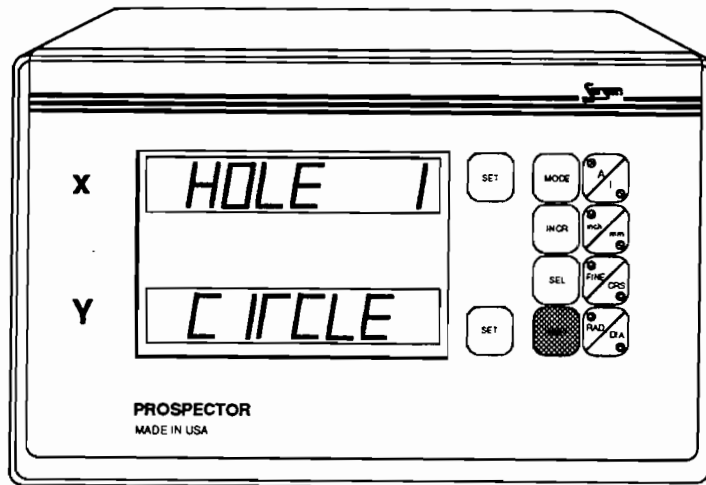

Figure 39: HOLE 1 CIRCLE (momentary)

Adjust the table until the display indicates 0,0. Then perform cutting operation and press NEXT. The DRO will then display the coordinates of holes 2, 3, and so on. Press NEXT each time you are ready to advance to the next step. When the holes are finished, the Prospector will display END OF CIRCLE (see Figure 40):

Note: Entering Run Mode automatically results in INCR Mode.

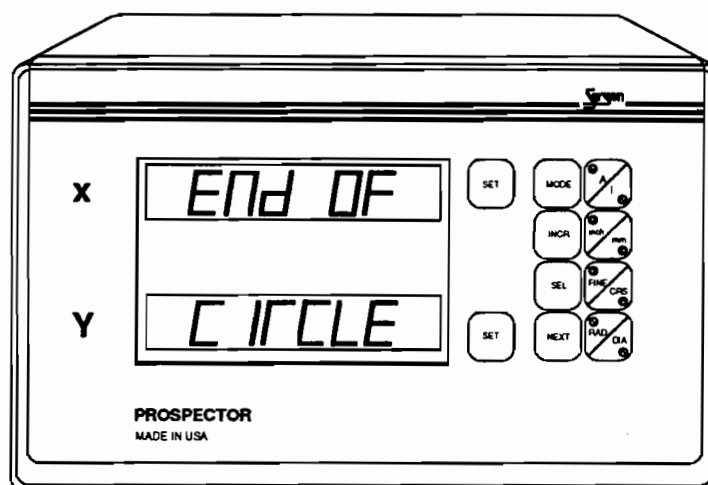

Figure 40: END OF CIRCLE

To continue around the same center, press NEXT after the momentary RETURN TO ZERO message is displayed and move the table to 0,0.

To exit Run Mode at any time, press MODE.

Running a Line-Hole Program

Choose LINE in the Run Mode by pressing by toggling to LINE using the SEL button or by pressing the corresponding SET button (see Figure 41).

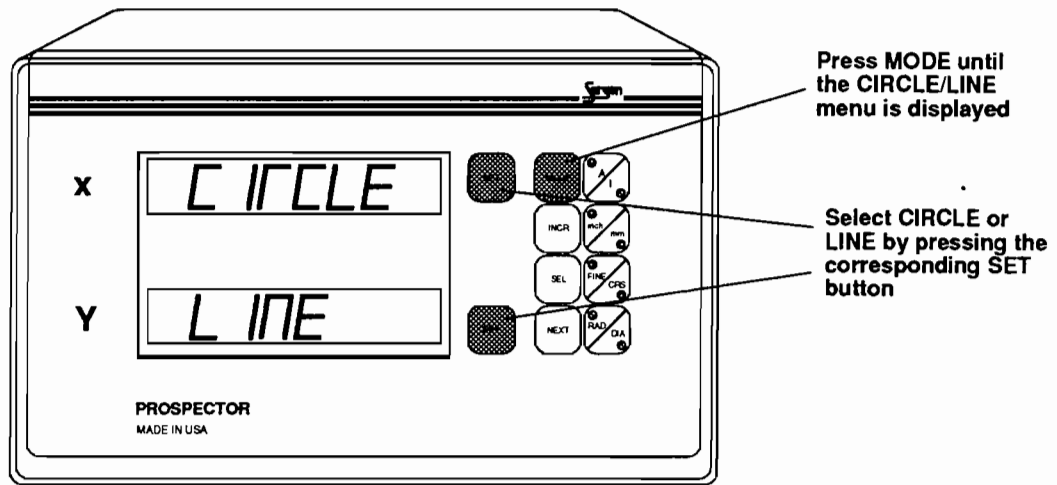

Figure 41: CIRCLE/LINE

Now press NEXT and the unit will display the following screens (Figures 42 and 43):

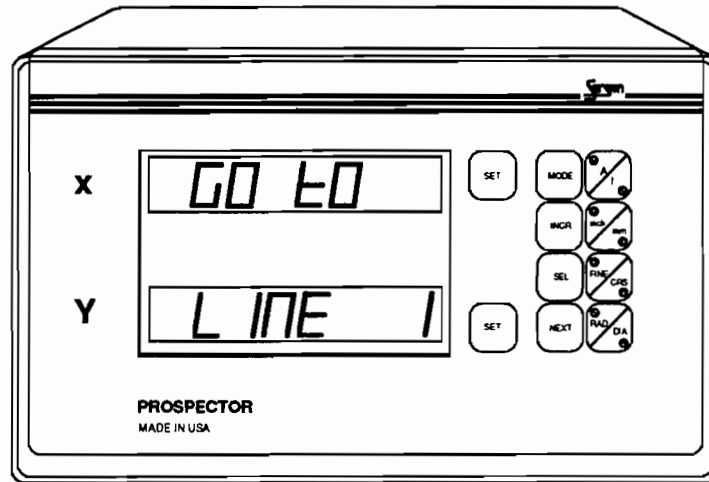

Figure 42: GO TO LINE 1 (momentary)

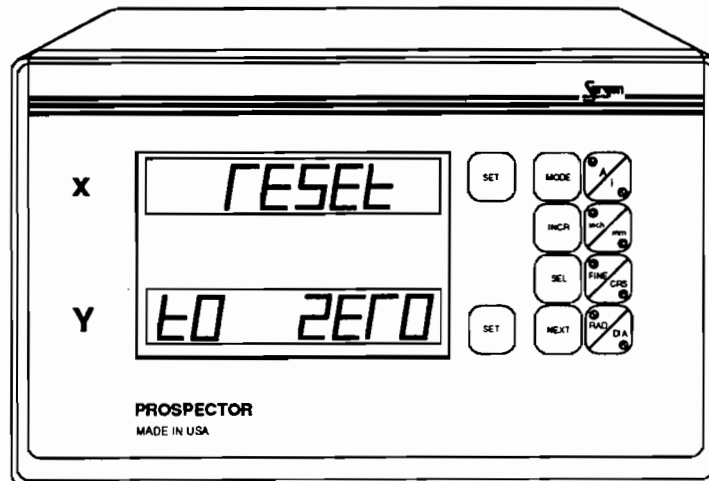

Figure 43: RESET TO ZERO (momentary)

In ABS Mode, move the table so that the spindle is pointing to the first hole. Then change to INCR Mode and zero the axes by pressing the SET buttons.

Adjust the table until the display indicates 0,0. The first hole is the starting position of the line, so perform cutting operation. Then press NEXT and move on to other holes. The DRO will display the coordinates of holes 2, 3, and so on. Press NEXT each time you are ready to advance to the next step. When the holes are finished, the Prospector will display END OF LINE (see Figures 44 and 45):

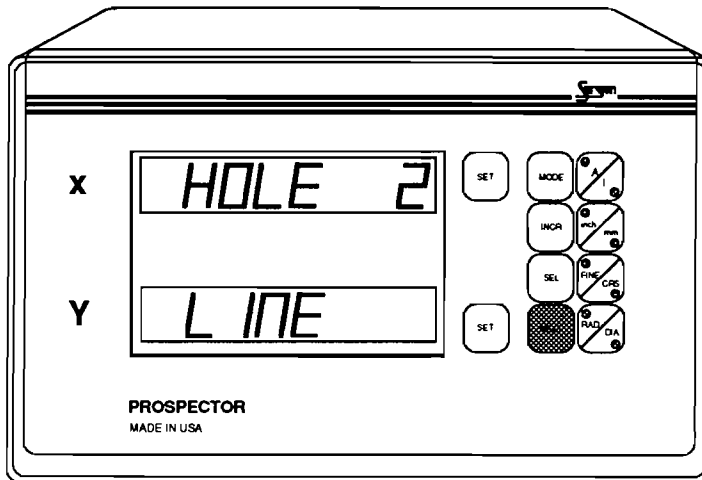

Figure 44: HOLE

Note: Entering Run Mode automatically results in INCR Mode.

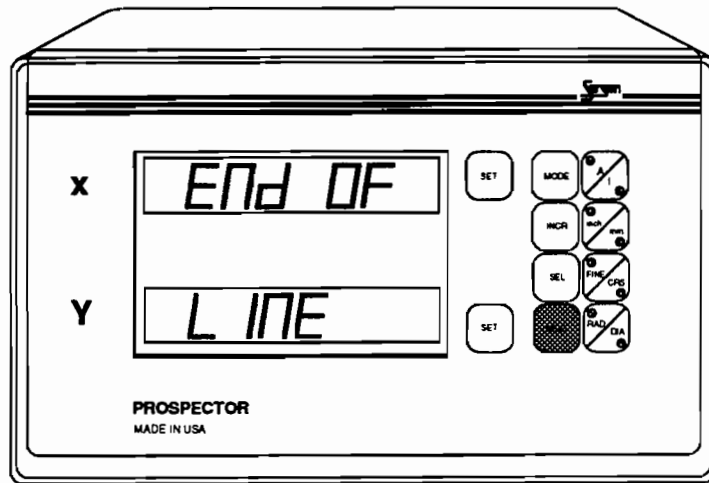

Figure 45: END OF LINE

To continue from the last hole, press NEXT after the momentary RETURN TO ZERO message is displayed, and move the table to 0,0.

To exit Run Mode at any time, press MODE.

On-Line Help

Press MODE until the words ON-LINE HELP are displayed (see Figure 46).

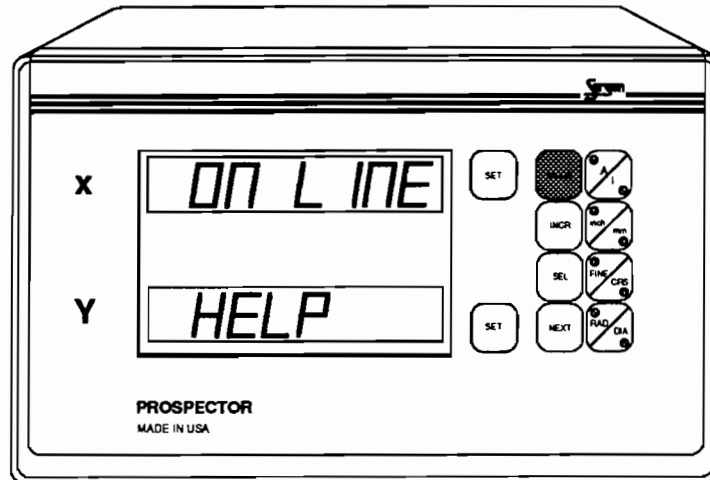

Figure 46: ON-LINE HELP

Then press SEL and the Prospector will run the existing bolt-hole and line-hole programs. If programs have been erased (eg, after CLEAR ALL), the DRO will use its sample demonstration programs stored in its permanent memory.

To stop continuous display of programs, press any button.

Machine Error Compensation (MEC)

A standard vertical milling machine would not have any error if its table movements followed perfectly straight lines. This, however, is not the case. There will always be some finite transfer error.

Machine error can be seen as the difference between the actual length of a standard gauge block and the value displayed by the digital readout. This error will also be present in any workpiece machined in that axis.

Machine Error Compensation (MEC) multiplies the internal display count by a conversion factor such that the displayed value will be correct. This factor is stored in the display's non-volatile memory and is set at the factory to a 1:1 ratio.

Example: A 10.0000 inch standard gauge block is measured on a knee mill using standard machine shop practices yielding a result of 10.0050 inch. MEC will re-proportion the dimension so that the display will then indicate the correct measurement of 10.0000 inches of travel. The 0.0050 inch error had been displaced within the 10.0000 inches of travel.

Displayed MEC factor range is from -0.999999 to +0.999999.

$$\text{MEC Factor} = \frac{\text{Measured Value} - \text{Gauge Value}}{\text{Measured Value}}$$

MEC should be a one time job. However, an operator may wish to recalibrate for a particular area on the machine table where a particular work is performed.

Although MEC can compensate for machine table problems, it is not intended as a substitute for proper machine maintenance.

Viewing the MEC Factor

Set the MEC switch on the back of the display to CAL and hold the A/I button (see Figure 47). The MEC factor will then be displayed. When finished, move the MEC switch back to OFF.

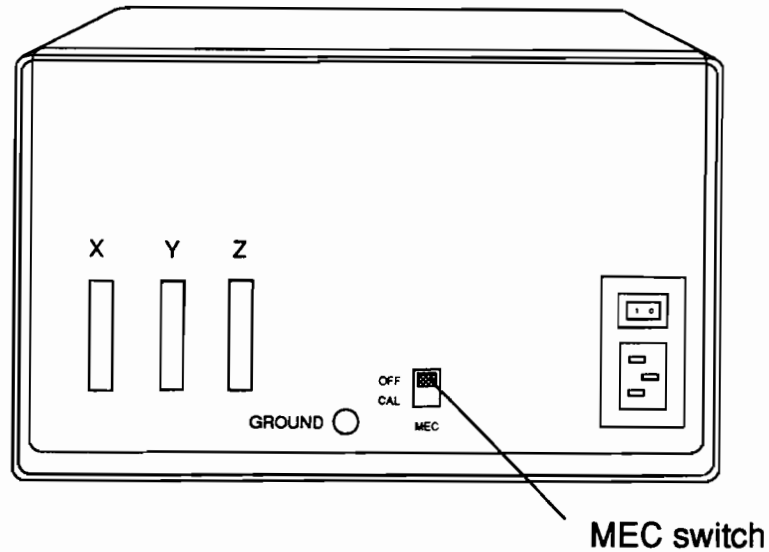

Figure 47

Clearing the MEC Factor

While viewing the MEC factors, press SET for selected axis(es) to reset the factor(s) to zero.

Calibrating MEC

Clear the MEC as described above. Set FINE/CRS switch to FINE and the RAD/DIA switch to RAD. Also, set the inch/mm switch to appropriate units in which you will perform your work.

Enter the actual certified gauge block length (refer to Preset Function and Numerical Data Entry). Set the MEC switch to CAL and press SET for selected axis.

Move table until the gauge block measurement is displayed. Set MEC switch to OFF. The value displayed will at this point be corrected to the certified gauge block length entered.

Repeat gauge block measurement to ensure unit is properly calibrated for that axis.

Repeat procedure for the remaining axes.

Note:

1. The MEC procedure is performed one axis at a time.
2. For best results, the display should be calibrated in units in which it will be used (inch or mm).
3. ABS and INC modes always have the same calibration factor for a given time.
4. Standard machine hop procedures are used for gauge block set up and measurement.

